

# PRESS BRAKE PRODUCTIVITY CATALOG





# INTRODUCTION

Putting the client first. That sounds quite lofty and many companies make this claim. But how does one actually implement this? At Wila, we have determined our client values. We want to offer valuable quality products and deliver quickly and reliably for an appealing price. We want to continuously improve these client values so that we can offer the market ever more valuable products.

This devotion is the source of inspiration for our development projects. In recent years, a range of innovations has been set in motion. Both in the areas of product development and process and organizational development.

The New Standard tool system for press brakes currently includes a wide range, which allows the sheet metal processing industry to achieve the highest degree of quality, productivity and longevity. To a large degree, the Wila production equipment has developed from labor-intensive to automated and robotized. Fabrication systems in which the operating equipment is fed with work pieces by robots from a buffer have already been introduced several years ago.

The introduction of a unit structure in the organization has resulted in more effective management and significantly improved results of the total business process. Per unit, the responsibility for progress, quality and improvement proposals is now in the hands of an executive who can also be held accountable for this. An increasingly broader implementation of parametric CAD/CAM solutions, robotic loading and software, which we developed in-house for the integral management of the business process, increase the flexibility, speed, reliability and cost-effectiveness. Especially this solid development of production technology and the work and cooperation method of employees will be paramount for the capacity of Wila to adapt to the demands of the market.

In this Press Brake Productivity Catalog we proudly present the results of our efforts. We serve the top segment of the market with a strengthened product line under the name New Standard Premium. In addition, with New Standard Pro we introduce a first-rate alternative for further differentiation in bending applications. This expansion will enable us to further adapt our products to a broad spectrum of industrial sectors. What about our other client values? I am challenging you to put us to the test!



**Hans Willemsen**

Managing Director Wila B.V.

# PRODUCT INDEX

<b>INTRODUCTION PRODUCT LINES</b>	<b>6</b>
<b>INTRODUCTION CLAMPING</b>	<b>8</b>
NEW STANDARD PREMIUM CLAMPING	10
NEW STANDARD PRO CLAMPING	12
AMERICAN STYLE CLAMPING	17
HYDRAULIC POWER PACKS	19
<b>INTRODUCTION NEW STANDARD PREMIUM AND PRO TOOLING</b>	<b>20</b>
GRIPPER	22
NEW STANDARD PREMIUM TOOLING	24
NEW STANDARD PRO TOOLING	42
MODIFIED TOP AND BOTTOM TOOLS (BMS, OMS)	44
<b>INTRODUCTION CUSTOM STYLE TOOLING</b>	<b>46</b>
CUSTOM STYLE ADJUSTABLE BOTTOM TOOLS	46
CUSTOM STYLE FLATTENING TOOLS	48
CUSTOM STYLE BOTTOM TOOL HOLDERS	66
CUSTOM MADE TOOLING	77
<b>INTRODUCTION CROWNING</b>	<b>50</b>
NEW STANDARD PREMIUM CROWNING	53
NEW STANDARD PRO CROWNING	54
AMERICAN STYLE CROWNING	57
CUSTOM STYLE CROWNING	60
<b>INTRODUCTION BOTTOM TOOL HOLDERS</b>	<b>62</b>
NEW STANDARD PREMIUM BOTTOM TOOL HOLDERS	64
NEW STANDARD PRO BOTTOM TOOL HOLDERS	65
CUSTOM STYLE BOTTOM TOOL HOLDERS	66
<b>INTRODUCTION ACCESSORIES</b>	<b>67</b>
NEW STANDARD ADAPTERS	68
NEW STANDARD TOOL HOLDERS AND INSERTS FOR OFFSETS AND FLATTENING	70
NEW STANDARD RADIUS TOOLING HOLDERS - RADIUS TOOLING INSERTS	71
NEW STANDARD NON-MARKING ACCESSORIES	72
NEW STANDARD FLATTENING TOOLS	73
CUSTOM STYLE ADAPTERS & EXTENDERS	74
PRESS BRAKE PRODUCTIVITY CABINET	76
<b>ALL SORTS OF INFORMATION</b>	<b>78</b>

# PRODUCT INDEX



## CLAMPING

Wila Clamping Systems are state of the art in every aspect. Their speed, reliability, safety, and overall performance are unrivaled. These qualities are packaged in a very compact design, without any external moving parts, providing maximum bending freedom. The clamping operation is quick and easy, and most often automatic.



## TOOLING

Perfectionists as we are at Wila, we leave nothing to chance. That holds true for our tooling range as well. Each tool model has been carefully selected and designed to fit into a tooling program that meets the many needs for bending a huge range of sheet parts in varying material types and thicknesses. The great selection of high quality tools means having the right tool available for practically any bending requirement.



## CROWNING

Wila Crowning Systems are recognized by their internal opposing wave technology (the "Wila Waves") allowing for centralized proportional crowning over the machine length while also providing localized adjustment capability. The resulting compact design is available in a wide range of models with automatic or manual operation for practically any press brake type or size.



## ACCESSORIES

To complement its Clamping, Crowning, and Tooling lines, Wila offers an extensive Accessories program to provide additional versatility to the sheet metal fabricator. Be it radius tooling, offset tooling, adjustable die systems, part marking prevention materials, or tooling storage systems, Wila has the solution for you.

## ALL SORTS OF INFORMATION

The pinnacle of productivity is having a minimum amount of effort producing a maximum result. That is the essence of our "productivity theory" for sustainable profitability. By thinking long term, productivity can be increased considerably. An investment in a Wila tooling system will pay for itself many times over in providing from day one much greater flexibility and consistently high quality parts. Put Wila's 75 years of bending know-how to work for you.

# INTRODUCING PRESS BRAKE PRODUCTIVITY FOR EVERY FABRICATOR

For over 75 years, Wila has supplied high quality products and support systems to improve press brake productivity. As part of the drive to enhance the productivity of press brakes, Wila developed its own tooling system: New Standard. This system distinguishes itself by a high degree of accuracy, speed, flexibility, durability, and safety. This top end product line is (re)named New Standard Premium™.

**NEW STANDARD**® PREMIUM  
The Cutting Edge of Press Brake Productivity

**NEW STANDARD**® PRO  
Wila Quality at an exceptional value

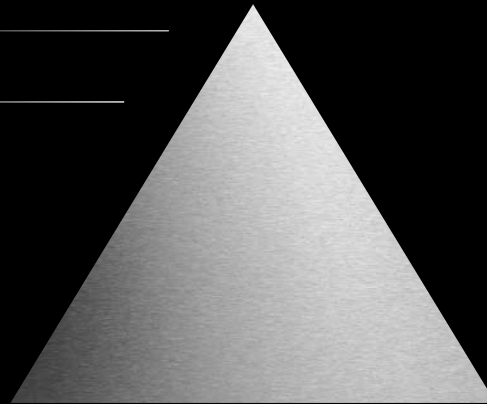

## The exact quality you need

In order to offer press brake productivity not only for the most demanding needs, Wila developed a new product line: New Standard Pro™. With this line Wila can offer the exact quality the customer requires: high performance, exceptional value. A promising novelty by Wila!

## NEW STANDARD PREMIUM

**Maximum productivity has a name.**

Wila's top product line is being renamed New Standard Premium™.

New Standard Premium™ is widely recognized for its extreme precision and durability, thanks to its CNC-Deepph hardened® and precision ground work surfaces.



## AMERICAN STYLE

**Advanced technology for American press brakes.**

Wila American Style has become well established as the premium Clamping, Crowning and Tooling system for American Style press brakes. With its fast set up time, high precision and durability, Wila American Style takes press brake productivity to a new level for American Style press brakes.

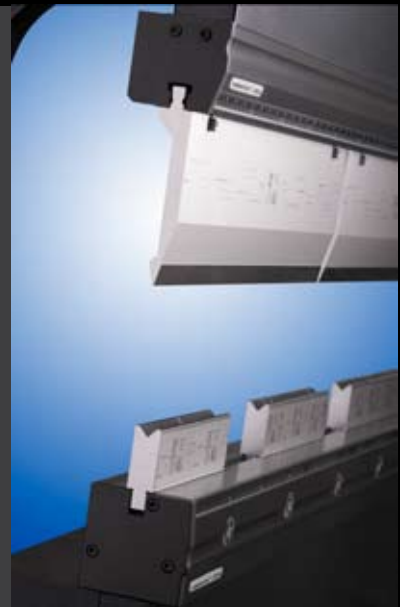

## NEW STANDARD PRO

**High performance, exceptional value.**

New Standard Pro make Wila productivity and quality even more affordable than even before. These new product lines have been developed to meet the needs of a wide range of manufacturers and are particularly attractive for the value provided for the investment. The combination of Clamping and Tooling provides the ultra-fast set-up time and high quality bending results that fabricators have come to expect from Wila.



# CLAMPING

Wila Clamping Systems are state of the art in every aspect. Their speed, reliability, safety, and overall performance are unrivaled. These qualities are packaged in a very compact design, without any external moving parts, providing maximum bending freedom. The clamping operation is quick and easy, and most often automatic.

Clamping is achieved by means of a flexible hose which is integrated in the clamping system over the entire length, whereby hydraulic oil pressure (max 50 Bar) is transferred to the tools via hardened clamping pins.

If tooling changeover is not often required, there are also manual clamping systems in the program to select from. In the manual systems, clamping bolts are pushed against a strip, which position and center the tools. When the clamping is activated, all tools are automatically seated, centered and aligned.

## **New Standard Premium Clamping**

The New Standard Premium Clamping systems offer the ultimate in precision, ease of operation, bending freedom, clamping performance, load bearing capacity and durability. The entire tool pressure surfaces are CNC-Dee-phardened® (approx. 56HRC) to minimize wear and provide a high level of performance and accuracy for the long term. The clamping has been designed in such a way that even tool segments as small as 10 mm can be clamped and positioned individually. Clamping is suitable for both head and shoulder bearing tools.

## **New Standard Pro Clamping**

For the clamping of New Standard top tools, Wila not only supplies the trend-setting New Standard Premium Clamping systems, but also high-quality alternatives for even more bending applications: New Standard Pro Clamping systems. The specifications of these clamping systems are similar in operation to the Premium clamping line with the main difference being that the pressure and reference surfaces are not hardened. With the New Standard Pro Clamping systems it is possible to clamp and position tool segments as small as 15 mm individually.





### American Style Clamping

Especially for the American market, Wila has designed and manufactures a variety of clamping systems that can be outfitted on new or current press brakes which automatically clamp, seat, center and align Wila American Style top tools. Also, other American style top tools can be clamped in Wila American Style Clamping, without self-seating, as long as the tools are outfitted with a safety tang.



### Maximum tool weight

For the mentioned clamping systems the maximum tool weight is :

CLAMPING TYPE		TOOL WEIGHT KG/METER
Premium	Hydraulic clamping system	300
	Manual clamping system	180
Pro	Hydraulic clamping system	100
	Manual clamping system	180
American Style	Hydraulic clamping system	75



### Hydraulic New Standard Clamping Systems for Automation

Together with Wila's Universal Press Brake Concept, with the optimal control of Tx alignment, and the New Standard tools, the hydraulic New Standard Clamping systems are especially suitable for automatic tool changeovers with the utilization of robots. You will find more information about this on page 22/23.

### Guard

All New Standard Premium Clamping systems come standard with Guards on the ends of the clamping units. All New Standard Pro Clamping systems and American Style Clamping systems can be outfitted with a Guard on the left and right end as an option. These Guards (see picture) have been provided with a cast steel insert to facilitate horizontal insertion of tools. In addition, the Guard prevents damage to the clamping systems and tools.

### The Wila New Standard and American Style Clamping systems offer:

- The fastest tool changeover.
- Automatic clamping, seating and aligning.
- Individual clamping of each tool segment.
- Vertical and horizontal tool changeover.
- Professional finish with an aluminum cover strip, including an integrated ruler.
- Available for use on all new or current press brakes.

### Hydraulic Power Pack

For all the hydraulic clamping systems, Wila supplies a suitable Hydraulic Power Pack with either remote control operation or operation via the press brake control. In case of fewer changeovers, the clamping can also be pressurized with an attractively priced manual pump, allowing you to take advantage of the flexibility of hydraulic clamping at a lower cost. With all clamping models, the hydraulic connection can be installed on either side of the clamping system. For more information about the Hydraulic Power Pack see also page 19.

**NSCL-II-HC/UPB**

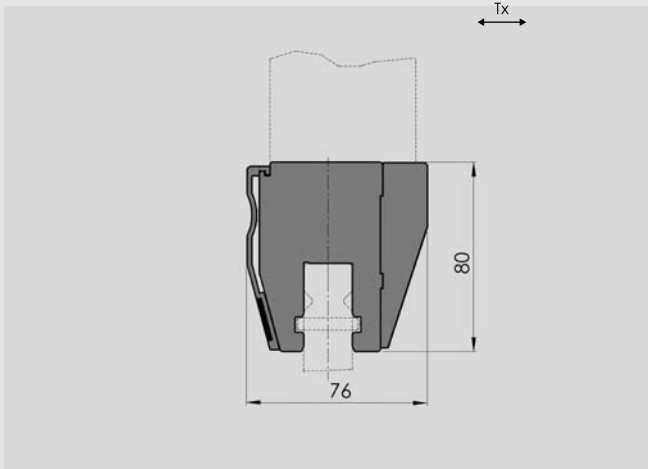

**NSCL-II-HC/UPB HYDRAULIC CLAMPING SYSTEM**

Hydraulic clamping system with X (Tx) alignment for the universal upper beam adaptation. Length built up from modules.

DELIVERY	STANDARD	OPTIONAL
Tooling adaptation CNC-Deephardened.	●	
Cover strip with scale	●	
Guards	●	
Hydraulic Power Pack*		●



LENGTH	WEIGHT KG	MAX LOAD	PRICE
1190 mm	38		
1530 mm	49		
1785 mm	57		
2040 mm	65	Head load	
2380 mm	76	250 T/meterw	
2550 mm	82	Shoulder load	
3060 mm	98	300 T/meter	
3655 mm	117		
4080 mm	131		
4250 mm	136		

**NSCL-II-MC/UPB**

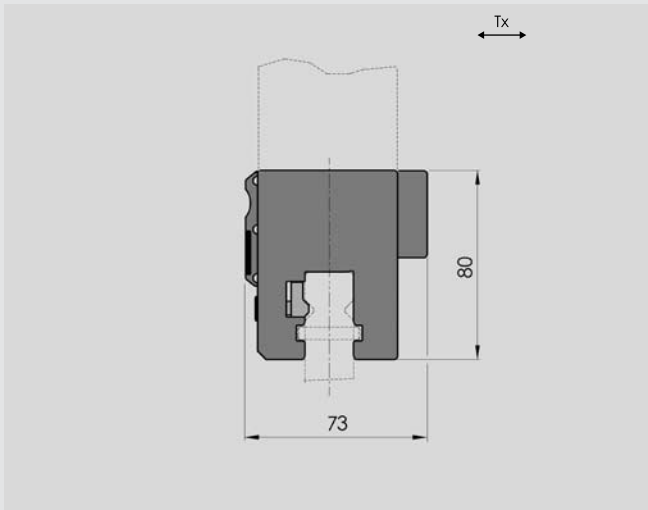

**NSCL-II-MC/UPB MANUAL CLAMPING SYSTEM**

Manual clamping system with X (Tx) alignment for the universal upper beam adaptation. Length built up from modules.

DELIVERY	STANDARD	OPTIONAL
Tooling adaptation CNC-Deephardened.	●	
Cover strip with scale	●	
Guards	●	



LENGTH	WEIGHT KG	MAX LOAD	PRICE
1190 mm	37		
1530 mm	47		
1785 mm	55		
2040 mm	63	Head load	
2380 mm	74	250 T/meter	
2550 mm	79	Shoulder load	
3060 mm	95	300 T/meter	
3655 mm	113		
4080 mm	126		
4250 mm	131		

**Note.:** For information about the standard equipment and options see page 8 and 9.  
\* Hydraulic Power Pack see page 19.

Other lengths available on request.



**NSCL-I-HC/UPB**

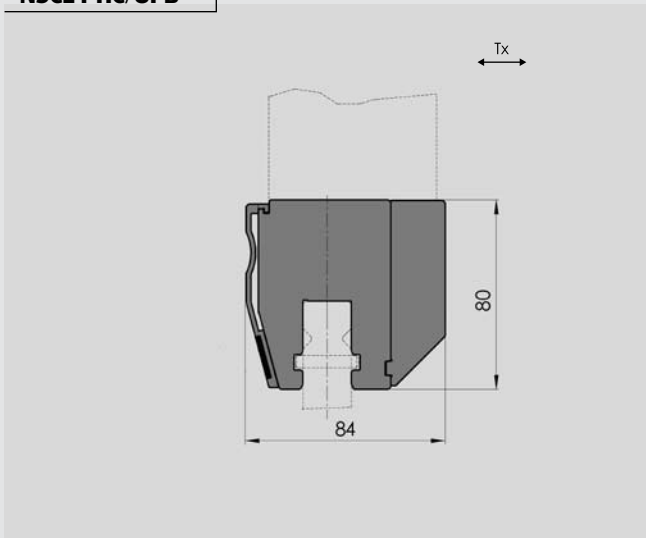

**NSCL-I-HC/UPB HYDRAULIC CLAMPING SYSTEM**

Hydraulic clamping system with X (Tx) alignment for the universal upper beam adaptation.

DELIVERY	STANDARD	OPTIONAL
Cover strip with scale	•	
Guards		•
Hydraulic Power Pack*		•

LENGTH	WEIGHT KG	MAX LOAD	PRICE
1190 mm	38		
1530 mm	49		
1785 mm	57		
2040 mm	65	Head load	
2380 mm	76	180 T/meter	
2550 mm	82	Shoulder load	
3060 mm	98	250 T/meter	
3655 mm	117		
4080 mm	131		
4250 mm	136		

**NSCL-I-MC/UPB**

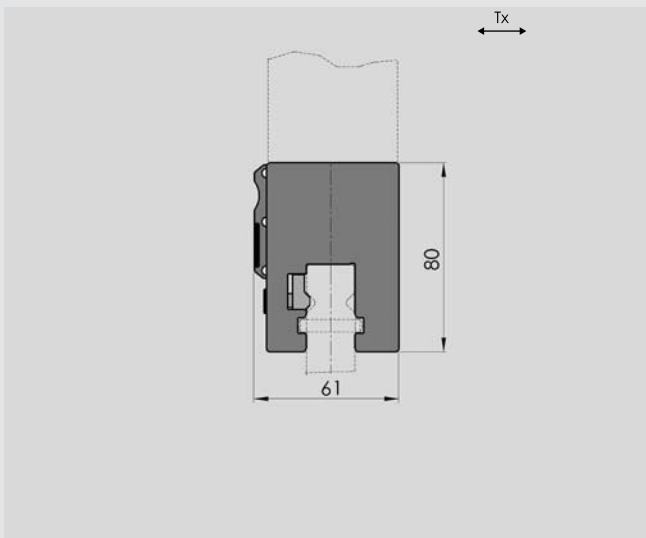

**NSCL-I-MC/UPB MANUAL CLAMPING SYSTEM**

Manual clamping system with X (Tx) alignment for the universal upper beam adaptation.

DELIVERY	STANDARD	OPTIONAL
Cover strip with scale	•	
Guards		•

LENGTH	WEIGHT KG	MAX LOAD	PRICE
1190 mm	35		
1530 mm	44		
1785 mm	52		
2040 mm	59	Head load	
2380 mm	69	180 T/meter	
2550 mm	74	Shoulder load	
3060 mm	89	250 T/meter	
3655 mm	106		
4080 mm	118		
4250 mm	123		

**Note:** For information about the standard equipment and options see page 8 and 9.  
\* Hydraulic Power Pack see page 19.

Other lengths available on request.

**NSCL-I-HC/ES I**

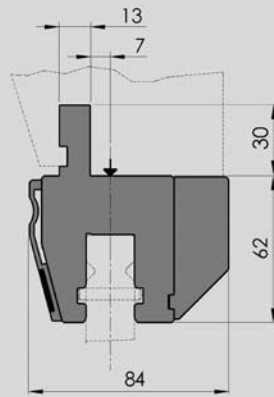

**NSCL-I-HC/ES I HYDRAULIC CLAMPING SYSTEM**

Hydraulic clamping system for European Style I upper beam adaptation.

DELIVERY	STANDARD	OPTIONAL
Cover strip with scale	●	
Guards		●
Hydraulic Power Pack*		●

LENGTH	WEIGHT KG	MAX LOAD	PRICE
1190 mm	31		
1530 mm	40		
1785 mm	47		
2040 mm	53	Head load	
2380 mm	62	180 T/meter	
2550 mm	67	Shoulder load	
3060 mm	80	250 T/meter	
3655 mm	95		
4080 mm	106		
4250 mm	111		

**NSCL-I-MC/ES I**

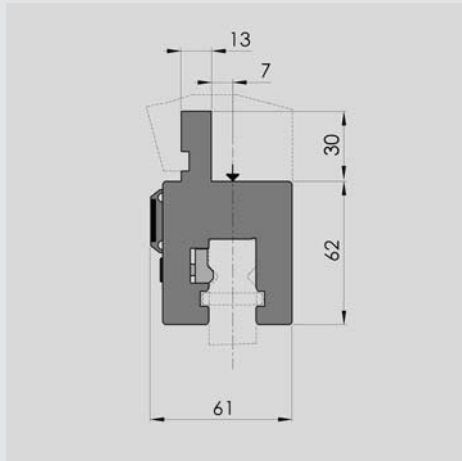

**NSCL-I-MC/ES I MANUAL CLAMPING SYSTEM**

Manual clamping system for European Style I upper beam adaptation.

DELIVERY	STANDARD	OPTIONAL
Cover strip with scale	●	
Guards		●

LENGTH	WEIGHT KG	MAX LOAD	PRICE
1190 mm	28		
1530 mm	36		
1785 mm	42		
2040 mm	48	Head load	
2380 mm	56	180 T/meter	
2550 mm	60	Shoulder load	
3060 mm	73	250 T/meter	
3655 mm	87		
4080 mm	97		
4250 mm	101		

**Note:** For information about the standard equipment and options see page 8 and 9.  
\* Hydraulic Power Pack see page 19.

Other lengths available on request.

**NSCL-I-HC/ES II**

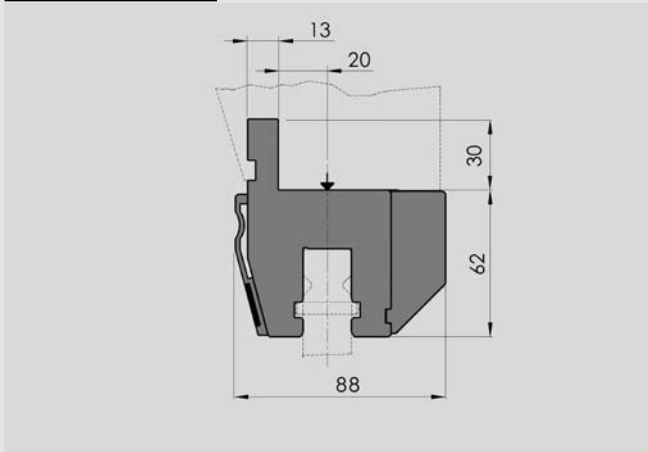

**NSCL-I-HC/ES II HYDRAULIC CLAMPING SYSTEM**

Hydraulic clamping system for European Style II upper beam adaptation.

DELIVERY	STANDARD	OPTIONAL
Cover strip with scale	•	
Guards		•
Hydraulic Power Pack*		•

LENGTH	WEIGHT KG	MAX LOAD	PRICE
1190 mm	33		
1530 mm	43		
1785 mm	50		
2040 mm	57	Head load	
2380 mm	67	180 T/meter	
2550 mm	72	Shoulder load	
3060 mm	86	250 T/meter	
3655 mm	103		
4080 mm	115		
4250 mm	119		

**NSCL-I-MC/ES II**

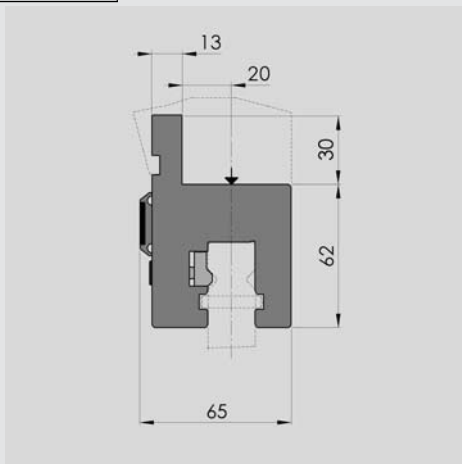

**NSCL-I-MC/ES II MANUAL CLAMPING SYSTEM**

Manual clamping system for European Style II upper beam adaptation.

DELIVERY	STANDARD	OPTIONAL
Cover strip with scale	•	
Guards		•

LENGTH	WEIGHT KG	MAX LOAD	PRICE
1190 mm	31		
1530 mm	39		
1785 mm	46		
2040 mm	52	Head load	
2380 mm	61	180 T/meter	
2550 mm	66	Shoulder load	
3060 mm	79	250 T/meter	
3655 mm	94		
4080 mm	105		
4250 mm	109		

**Note:** For information about the standard equipment and options see page 8 and 9.  
\* Hydraulic Power Pack see page 19.

Other lengths available on request.

**NSCL-I-HC/AS I**

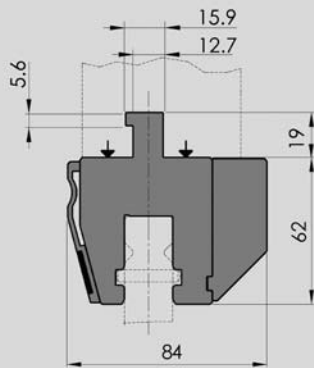

**NSCL-I-HC/AS I HYDRAULIC CLAMPING SYSTEM**

Hydraulic clamping system for American Style I upper beam adaptation.

DELIVERY	STANDARD	OPTIONAL
Cover strip with scale	●	
Guards		●
Hydraulic Power Pack*		●

LENGTH	WEIGHT	MAX LOAD	PRICE
	KG		
1190 mm	30		
1530 mm	39		
1785 mm	45		
2040 mm	51	Head load	
2380 mm	60	180 T/meter	
2550 mm	64	Shoulder load	
3060 mm	77	250 T/meter	
3655 mm	92		
4080 mm	103		
4250 mm	107		

**NSCL-I-MC/AS I**

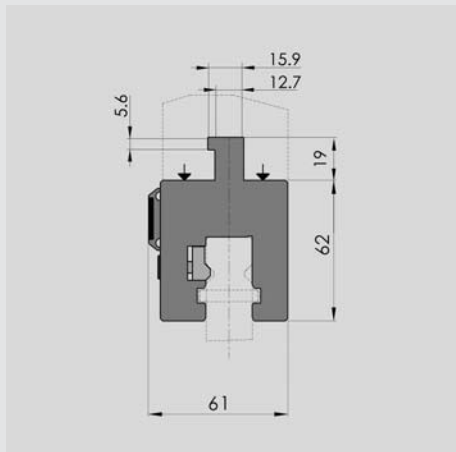

**NSCL-I-MC/AS I MANUAL CLAMPING SYSTEM**

Manual clamping system for American Style I upper beam adaptation.

DELIVERY	STANDARD	OPTIONAL
Cover strip with scale	●	
Guards		●

LENGTH	WEIGHT	MAX LOAD	PRICE
	KG		
1190 mm	27		
1530 mm	35		
1785 mm	41		
2040 mm	47	Head load	
2380 mm	55	180 T/meter	
2550 mm	58	Shoulder load	
3060 mm	70	250 T/meter	
3655 mm	84		
4080 mm	93		
4250 mm	97		

**Note:** For information about the standard equipment and options see page 8 and 9.  
\* Hydraulic Power Pack see page 19.

Other lengths available on request.

**NSCL-I-MC-segm./ES I**

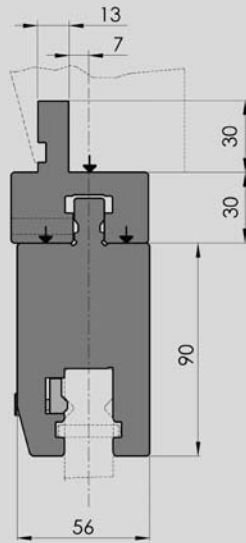

**NSCL-I-MC-segm./ES I MANUAL CLAMPING SYSTEM**

Segmented holder for European Style I upper beam adaptation.  
Top part full machine length, bottom part segmented in lengths of 150 mm.

DELIVERY	STANDARD	OPTIONAL
Bottom part, 1 extender every 200 mm	●	
Additional extenders		●

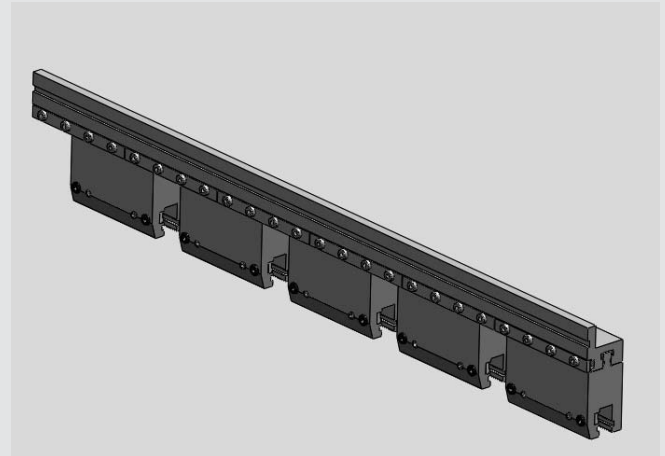

LENGTH	WEIGHT KG	MAX LOAD	PRICE
1190 mm	50		
1530 mm	65		
1785 mm	75		
2040 mm	84	Head load	
2380 mm	99	180 T/meter	
2550 mm	108	Shoulder load	
3060 mm	126	250 T/meter	
3655 mm	150		
4080 mm	167		
4250 mm	176		

**NSCL-I-MC-segm./ES II**

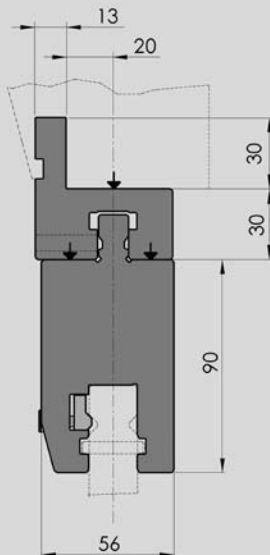

**NSCL-I-MC-segm./ES II MANUAL CLAMPING SYSTEM**

Segmented holder for European Style II upper beam adaptation.  
Top part full machine length, bottom part segmented in lengths of 150 mm.

DELIVERY	STANDARD	OPTIONAL
Bottom part, 1 extender every 200 mm	●	
Additional extenders		●

LENGTH	WEIGHT KG	MAX LOAD	PRICE
1190 mm	50		
1530 mm	65		
1785 mm	75		
2040 mm	84	Head load	
2380 mm	99	180 T/meter	
2550 mm	108	Shoulder load	
3060 mm	126	250 T/meter	
3655 mm	150		
4080 mm	167		
4250 mm	176		

**Note:** For information about the standard equipment and options see page 8 and 9.

Other lengths available on request.



## ASCL-I-HC/UPB

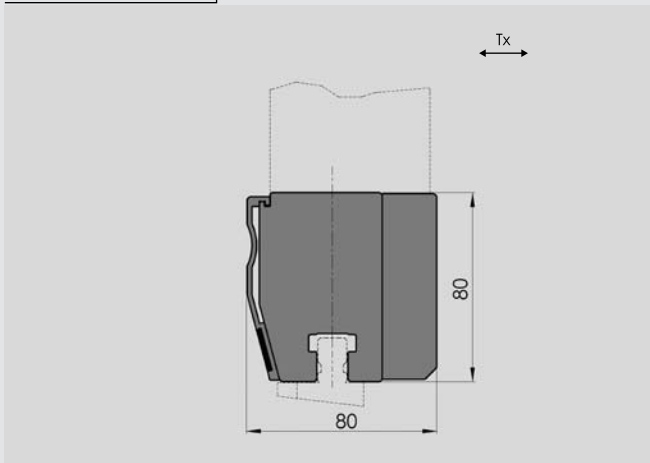

LENGTH	WEIGHT KG	MAX LOAD	PRICE
1190 mm	41	Shoulder load 230 T/meter	
1530 mm	52		
1785 mm	61		
2040 mm	70		
2380 mm	81		
2550 mm	87		
3060 mm	105		
3655 mm	125		
4080 mm	140		
4250 mm	145		

## ASCL-I-HC/UPB HYDRAULIC CLAMPING SYSTEM

Hydraulic clamping system with X (Tx) alignment for the universal upper beam adaptation.

DELIVERY	STANDARD	OPTIONAL
Cover strip with scale	•	
Guards		•
Hydraulic Power Pack*		•

## ASCL-I-MC/UPB

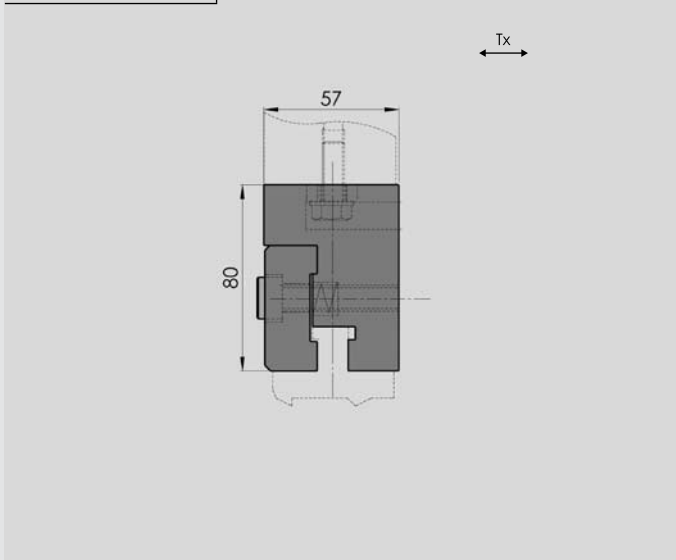

LENGTH	WEIGHT KG	MAX LOAD	PRICE
1190 mm	23	Shoulder load 230 T/meter	
1530 mm	30		
1785 mm	35		
2040 mm	40		
2380 mm	47		
2550 mm	50		
3060 mm	60		
3655 mm	72		
4080 mm	80		
4250 mm	83		

## ASCL-I-MC/UPB MANUAL CLAMPING SYSTEM

Manual clamping system with X (Tx) alignment for the universal upper beam adaptation.

Previously the ACL 802

**Note:** For information about the standard equipment and options see page 8 and 9.

\* Hydraulic Power Pack see page 19.

Other lengths available on request.

**ASCL-I-HC/ES II**

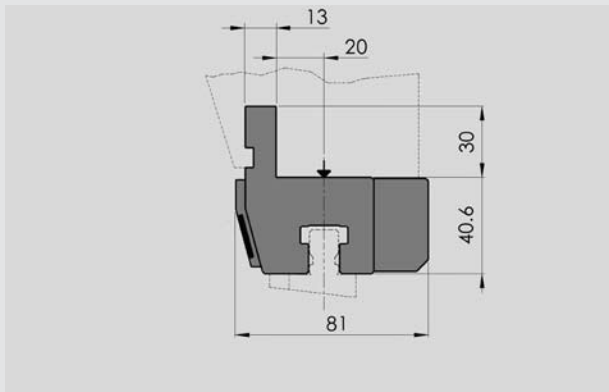

**ASCL-I-HC/ES II HYDRAULIC CLAMPING SYSTEM**

Hydraulic clamping system for European Style II upper beam adaptation.

DELIVERY	STANDARD	OPTIONAL
Cover strip with scale	•	
Guards		•
Hydraulic Power Pack*		•
ES I adaptation		•

LENGTH	WEIGHT KG	MAX LOAD	PRICE
1190 mm	22		
1530 mm	29		
1785 mm	34		
2040 mm	38		
2380 mm	45	Shoulder load 230 T/meter	
2550 mm	48		
3060 mm	58		
3655 mm	69		
4080 mm	77		
4250 mm	80		

**ASCL-I-HC/AS I**

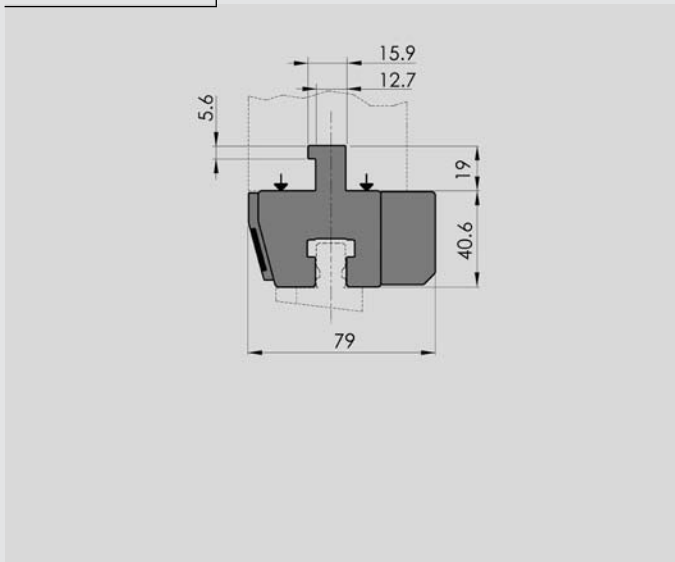

**ASCL-I-HC/AS I HYDRAULIC CLAMPING SYSTEM**

Hydraulic clamping system for American Style I upper beam adaptation.

DELIVERY	STANDARD	OPTIONAL
Cover strip with scale	•	
Guards		•
Hydraulic Power Pack*		•



LENGTH	WEIGHT KG	MAX LOAD	PRICE
1190 mm	21		
1530 mm	28		
1785 mm	32		
2040 mm	37		
2380 mm	43	Shoulder load 230 T/meter	
2550 mm	46		
3060 mm	55		
3655 mm	66		
4080 mm	73		
4250 mm	77		

**Note:** For information about the standard equipment and options see page 8 and 9.  
\* Hydraulic Power Pack see page 19.

Other lengths available on request.



Hydraulic-Power Pack HM10 and HM11 type H-R (with remote control)

Hydraulic Power Pack HM10 and HM11 type H (Manual operation) or C (linked to the CNC control)

## HYDRAULIC POWER PACK FOR USE IN COMBINATION WITH CLAMPING, CROWNING, BOTTOM TOOL HOLDERS & (A3) CLAMPING BARS.

TYPE	OPMERKINGEN	PRIJS
HM10-400-H	Manual operation <sup>1</sup> , 400V-50Hz-3ph	
HM10-400-H-R	Manual operation <sup>2</sup> , 400V-50Hz-3ph	
HM10-400-C	Linked to the CNC control, 400V-50Hz-3ph	
HM11-460/230-H dual voltage	Manual operation <sup>1</sup> , 230/460V-60Hz-3ph, supplied at 460V	
HM11-460/230-H-R dual voltage	Manual operation <sup>2</sup> , 230/460V-60Hz-3ph, supplied at 460V	
HM11-230/460-H dual voltage	Manual operation <sup>1</sup> , 230/460V-60Hz-3ph, supplied at 230V	
HM11-230/460-H-R dual voltage	Manual operation <sup>2</sup> , 230/460V-60Hz-3ph, supplied at 230V	
HM12-460/230 dual voltage	Fully integratable in the press brake <sup>3</sup> , valve 24 V supplied at 460V	
HM13-400	Fully integratable in the press brake <sup>3</sup> , valve 24 V	
Manual pump	Manual operation with hand lever and relief valve	
Extra hydraulic hose	Hose L=2,5 meter equipped with straight fitting and fitting for extra hose	

### Comments.

- 1) Operation via push button on the power pack.
  - 2) Comes with a remote control.
  - 3) Only for press brake manufacturers
- All hydraulic power packs have a Ø10 connection and are supplied with one hose measuring 2.5 meters.
  - All Hydraulic Power Packs with dual voltage have been specially developed for the North American market.



Manual pump

# NEW STANDARD PREMIUM & PRO TOOLING

Perfectionists as we are at Wila, we leave nothing to chance. That holds true for our tooling range as well. Each tool model has been carefully selected and designed to fit into a tooling program that meets the many needs for bending a huge range of sheet parts in varying material types and thicknesses. The great selection of high quality tools means having the right tool available for practically any bending requirement.

## Safety-Click®

The essence of the New Standard top tools is the patented safety mechanism Safety-Click®, which is part of the top tool. This enables the vertical changeover of tool segments by simply clicking them in and out of the holder vertically. Safety-Click® also makes it possible to automatically change the tools with a robot, see page 22/23.

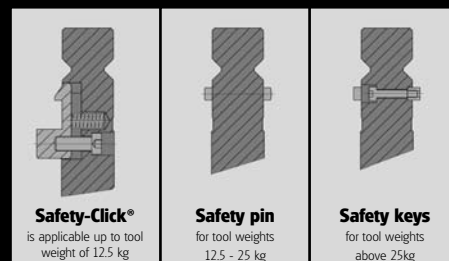

## New Standard Premium

High-tech perfection at the highest level. No matter how demanding your requirements and how tight your tolerances are, you always have the best tools available with New Standard Premium, even for the most extreme applications. Starting with the use of a special CrMo steel alloy, the quality of the tool construction is unsurpassed. New Standard Premium tools are specially CNC-Deepharden® and have a high-quality finish for an extremely long life span along with the highest degree of precision - even with very tall tools.

## New Standard Pro

New Standard Pro Tooling has been developed for those applications where tools with a relatively limited work height are sufficient. This product line is particularly suitable for bending applications where less extreme requirements are set. New Standard Pro is directly derived from the well-known Wila tooling range. The intelligent combination of the clamping system and precision tool guarantees perfect and consistent bending results. Your press brake productivity is always our primary concern. With New Standard Pro, additional versatility is provided at very attractive pricing.

## FACTSHEET

### NEW STANDARD® PREMIUM

### NEW STANDARD® PRO

Material	High tensile CrMo steel alloy, $\geq 1,000$ N/mm <sup>2</sup> minimum for maximum durability.	High quality tool steel, suitable to meet the demands for all normal bending jobs.
Hardening	All Bending radii are CNC-Deeaphardened® to 56° Rc minimum, width a depth of $\geq 4$ mm for maximum longevity.	All bending radii are CNC-Deeaphardened® to 52° Rc minimum to a depth of 2 mm for long tool life.
Accuracy	All working surfaces are precision ground to +/- 0.01 mm for highest accuracy (adequate for V=6*S).	All working surfaces are precision ground to +/- 0.02 mm (adequate for V=8*S).

### The advantages of New Standard Tooling

- Quick and easy tool exchange .
- Unsurpassed in speed and precision.
- New Standard Premium and New Standard Pro tools can be used in the same clamping system
- Exceptionally precise, safe and flexible.
- Construction according to the high Wila standards.
- Exceptionally long life span.

### Standard program

The Wila standard program includes a broad range of tools in the categories New Standard Premium and New Standard Pro.

#### • Top tools (BIU)

Suitable for all New Standard Premium and New Standard Pro clampings.

#### • Bottom tools (OZU)

To be used on all press brakes fitted with a clamping slot measuring 13.5 x 22 mm (WxH)

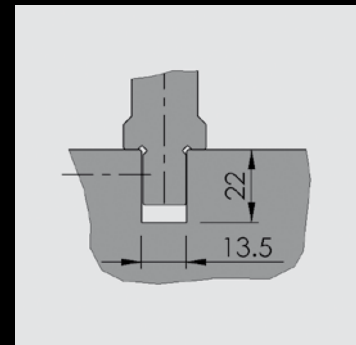

Clamping Slot

The OZU's with a work height of 100 mm in the New Standard Premium program and the New Standard Pro OZU's are provided with extra large bending radii (approx. 20% of the V-opening) as standard. With these large shoulder radii marking on the sheet material will be minimal, while any protective foil will stay intact much longer.

### Different tools, same advantages

Despite the differences in function, geometry and clamping principle, all New Standard tools have the same advantages:

- New Standard Premium tools are available for both air bending and bottom bending.
- All tools are delivered modularly in a number of standard lengths. This way, any working length can be accomplished in increments of 5 mm.

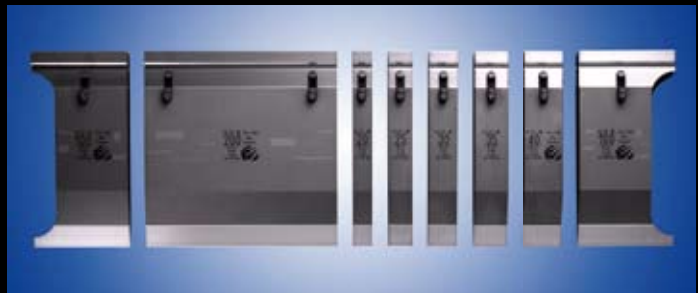

New Standard Premium segmented set

### Available standard lengths

INDICATION	PREMIUM		PRO		
	TOP	BOTTOM	TOP	BOTTOM	
/1	•	•	•	•	L=515 mm
/2*	•	•			L=550 mm (Horn left & right L=100 mm + L=20-25-30-35-40-200 mm)
/3	•		•	•	L=200 mm (100-100 mm) no horns
/6	•	•			L=200 mm
/10			•	•	L= 475 mm (20-25-30-35-40-125-100-100) no horns
/11			•		L= 200 mm (2 x Horn L=100 left & right)

\* Bottom tools come without horns

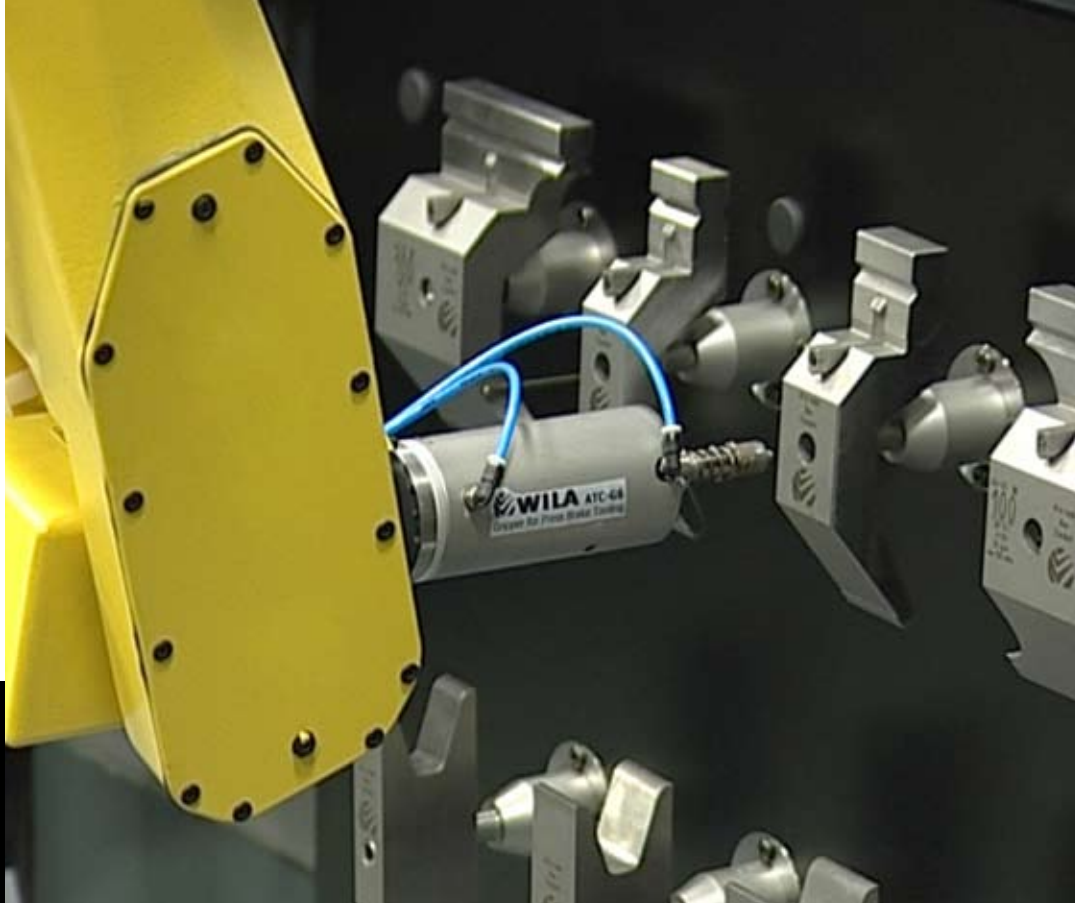

## TOOLING

# GRIPPER®

### Automatic Tool Change (ATC)

With the introduction of the ATC-G6 Gripper, Wila makes it possible for robotic press brakes to bend small batches of various products in random order fully automatically. Now bending on demand has been made possible.

By automating tool change overs, the tooling set-up in your press brake is no longer the limiting factor in the variety of parts that can be formed entirely unman-  
ned. The robot or the manipu-  
lator changes its part gripper to the ATC-G6 Gripper, changes the tooling set-up very quickly, and is ready to bend the next part(s).



**GRIPPER ATC-G6**

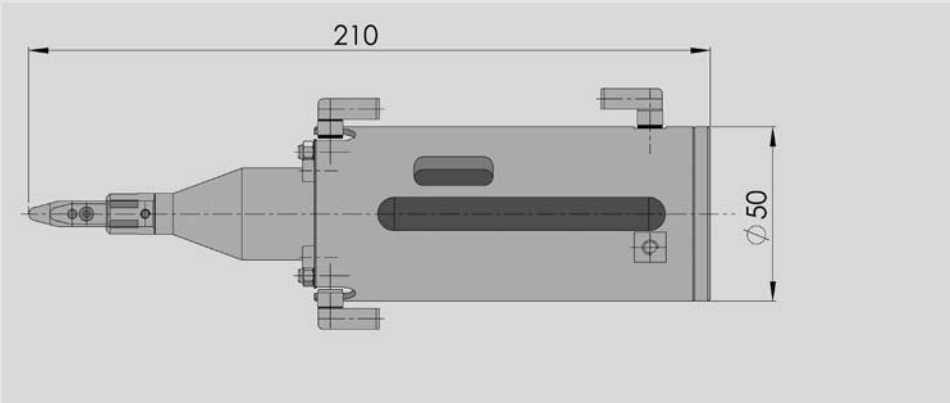

Allows automatic loading and unloading of all current models of our New Standard tooling program.  
The robot tool changer is not included.

**Docking Station**

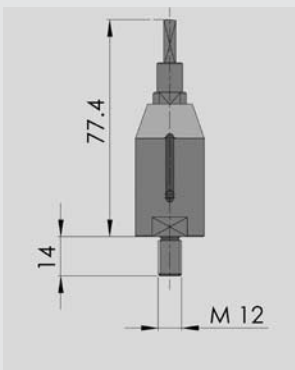

Holds all current models of our New Standard tooling program that are prepared for automatic loading and unloading.  
Can be placed in every horizontal position within the reach of the robot.

**ATC-Adaptor BIU**

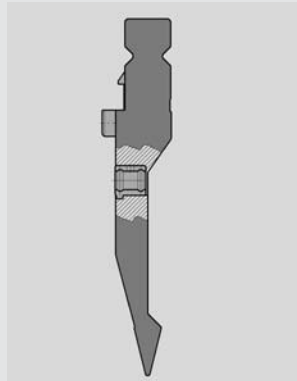

All New Standard top tools (BIU) with lengths from 20 –100 mm, when equipped with this ATC-Adaptor, can be automatically loaded and unloaded by the ATC-6G Gripper. In this case the ATC-6G Gripper will operate the Safety-Click®! Max tool weight is 15 kg. Adaptor can be placed in new and existing BIU top tools.

**ATC-Adaptor OZU**

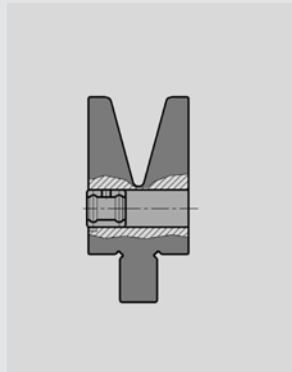

All New Standard bottom tools (OZU) with lengths from 20 –100 mm, when equipped with this ATC-Adaptor, can be automatically loaded and unloaded by the ATC-6G gripper. Max tool weight is 15 kg. Adaptor can be placed in new and existing OZU bottom tools.

**ATC-G6 Gripper specifications**

Size	Ø50 *210 mm
Weight	1,5 kg
Change-over time	5 seconds
Max. tool weight	15 kg
Min. ~ max. tool length	20 ~ 100 mm
Tool shapes	handles all the Wila New Standard top and bottom tool models

**BIU-001**

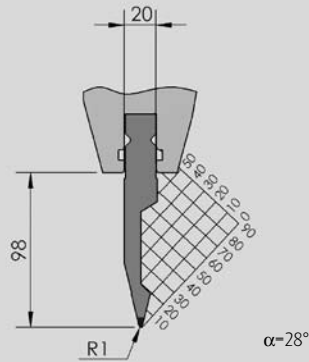

**BIU-011**

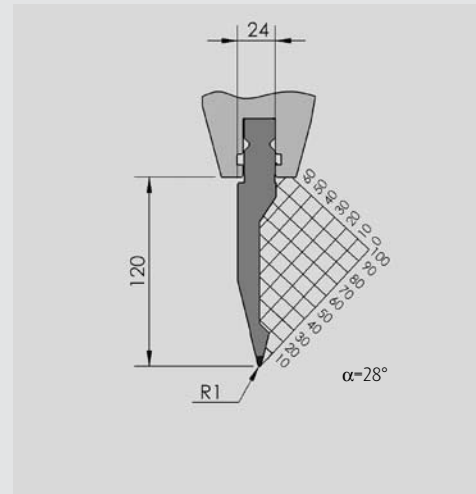

**BIU-021**

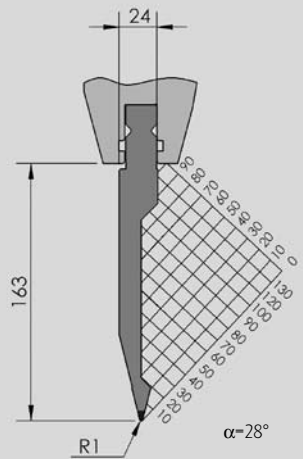

**BIU-031**

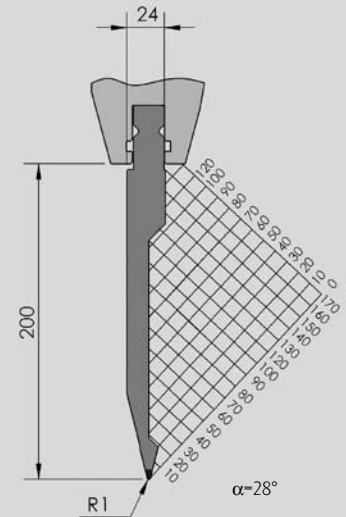

TYPE	LENGTH	WEIGHT KG	MAX LOAD	PRICE
BIU-001/1	515 mm	75	100 T/Mtr.	.....
BIU-001/2	550 mm - sectioned	8.0		.....
BIU-001/3	200 mm - sectioned	2.9		.....
BIU-001/6	200 mm	2.9		.....
BIU-011/1	515 mm	9.5	100 T/Mtr.	.....
BIU-011/2	550 mm - sectioned	10.2		.....
BIU-011/3	200 mm - sectioned	3.7		.....
BIU-011/6	200 mm	3.7		.....
BIU-021/1	515 mm	12.4	70 T/Mtr.	.....
BIU-021/2	550 mm - sectioned	13.2		.....
BIU-021/3	200 mm - sectioned	4.8		.....
BIU-021/6	200 mm	4.8		.....
BIU-031/1	515 mm*	15.0	60 T/Mtr.	.....
BIU-031/2	550 mm - sectioned	16.1		.....
BIU-031/3	200 mm - sectioned	5.8		.....
BIU-031/6	200 mm	5.8		.....

\* provided with fixed safety pins (see page 20/21).



**BIU-061**

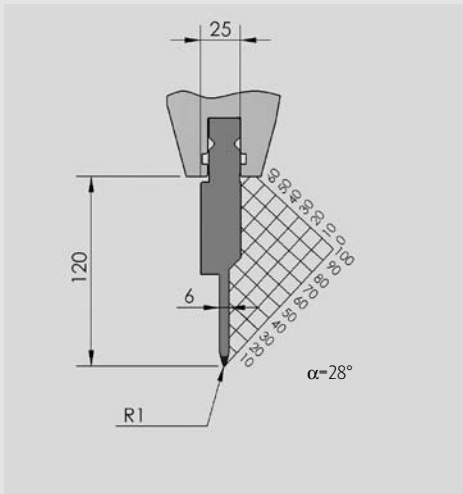

**BIU-051**

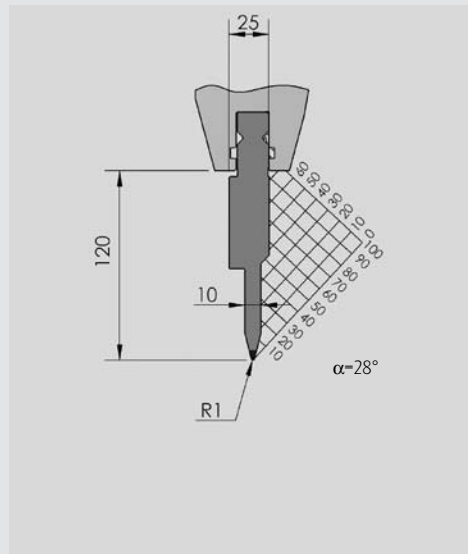

**BIU-063**

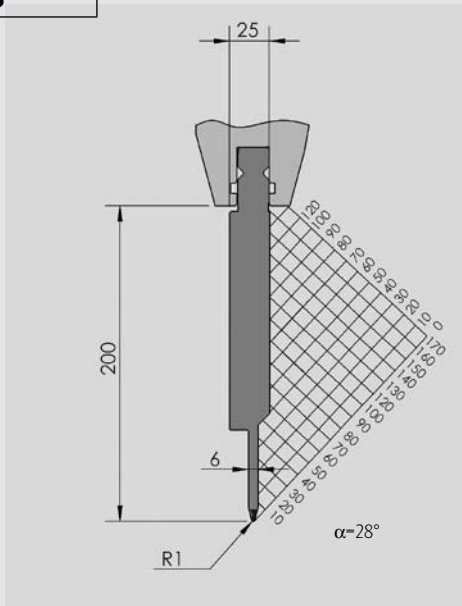

**BIU-053**

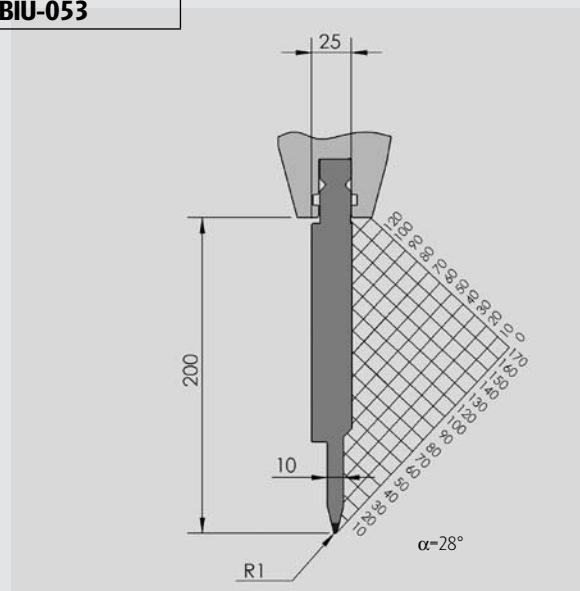

TYPE	LENGTH	WEIGHT KG	MAX LOAD	PRICE
BIU-061/1	515 mm	10.4	50 T/Mtr.	
BIU-061/2	550 mm - sectioned	11.1		
BIU-061/3	200 mm - sectioned	4.0		
BIU-061/6	200 mm	4.0		
BIU-051/1	515 mm	11.3	100 T/Mtr.	
BIU-051/2	550 mm - sectioned	12.1		
BIU-051/3	200 mm - sectioned	4.4		
BIU-051/6	200 mm	4.4		
BIU-063/1	515 mm*	19.5	50 T/Mtr.	
BIU-063/2	550 mm - sectioned	20.8		
BIU-063/3	200 mm - sectioned	7.6		
BIU-063/6	200 mm	7.6		
BIU-053/1	515 mm*	19.5	100 T/Mtr.	
BIU-053/2	550 mm - sectioned	20.8		
BIU-053/3	200 mm - sectioned	7.6		
BIU-053/6	200 mm	7.6		

\* provided with fixed safety pins (see page 20/21).

**BIU-004**

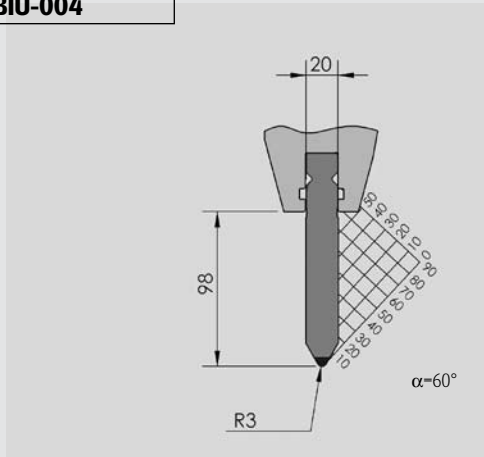

**BIU-014**

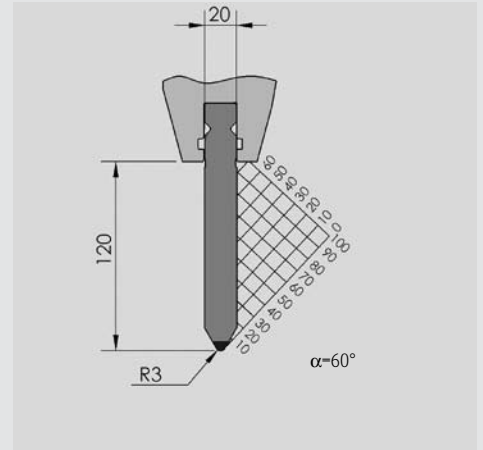

**BIU-024**

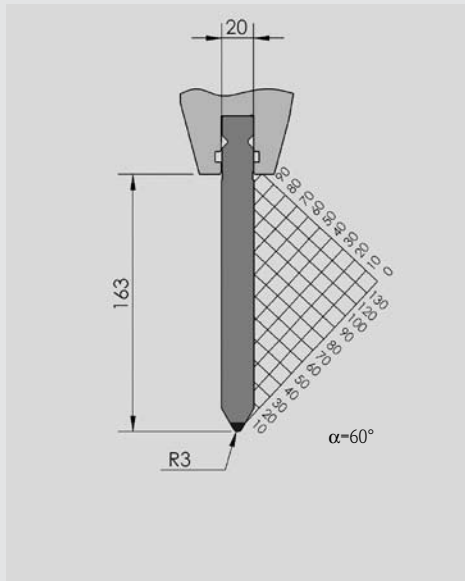

**BIU-034**

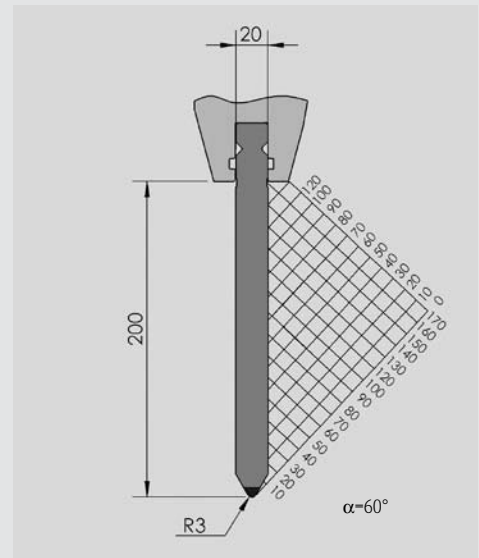

TYPE	LENGTH	WEIGHT KG	MAX LOAD	PRICE
BIU-004/1	515 mm	10.6	160 T/Mtr.	
BIU-004/2	550 mm - sectioned	11.3		
BIU-004/3	200 mm - sectioned	4.1		
BIU-004/6	200 mm	4.1		
BIU-014/1	515 mm	12.2	160 T/Mtr.	
BIU-014/2	550 mm - sectioned	13.0		
BIU-014/3	200 mm - sectioned	4.7		
BIU-014/6	200 mm	4.7		
BIU-024/1	515 mm*	16.0	160 T/Mtr.	
BIU-024/2	550 mm - sectioned	17.1		
BIU-024/3	200 mm - sectioned	6.2		
BIU-024/6	200 mm	6.2		
BIU-034/1	515 mm*	18.8	160 T/Mtr.	
BIU-034/2	550 mm - sectioned	20.1		
BIU-034/3	200 mm - sectioned	7.3		
BIU-034/6	200 mm	7.3		

\* provided with fixed safety pins (see page 20/21).

**BIU-002**

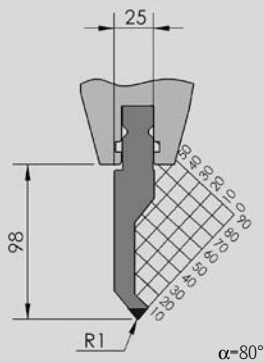

**BIU-012**

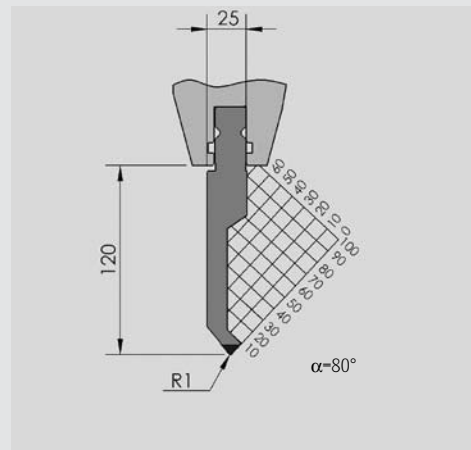

**BIU-022**

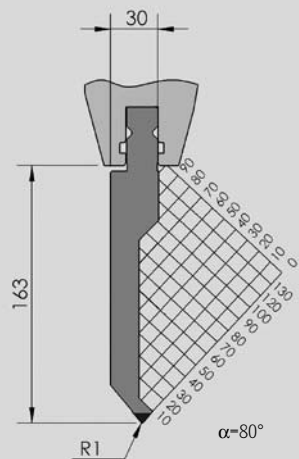

**BIU-032**

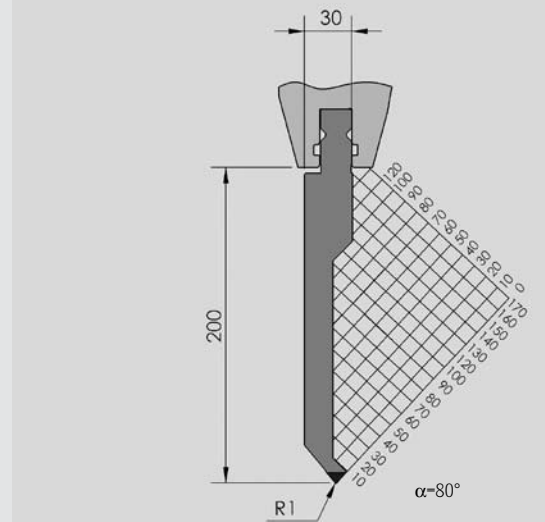

TYPE	LENGTH	WEIGHT KG	MAX LOAD	PRICE
BIU-002/1	515 mm	9.1	100 T/Mtr.	
BIU-002/2	550 mm - sectioned	9.7		
BIU-002/3	200 mm - sectioned	3.5		
BIU-002/6	200 mm	3.5		
BIU-012/1	515 mm	10.8	100 T/Mtr.	
BIU-012/2	550 mm - sectioned	11.6		
BIU-012/3	200 mm - sectioned	2.2		
BIU-012/6	200 mm	2.3		
BIU-022/1	515 mm*	16.2	80 T/Mtr.	
BIU-022/2	550 mm - sectioned	17.3		
BIU-022/3	200 mm - sectioned	6.3		
BIU-022/6	200 mm	6.3		
BIU-032/1	515 mm*	19.8	70 T/Mtr.	
BIU-032/2	550 mm - sectioned	21.1		
BIU-032/3	200 mm - sectioned	7.7		
BIU-032/6	200 mm	7.7		

\* provided with fixed safety pins (see page 20/21).

**BIU-029**

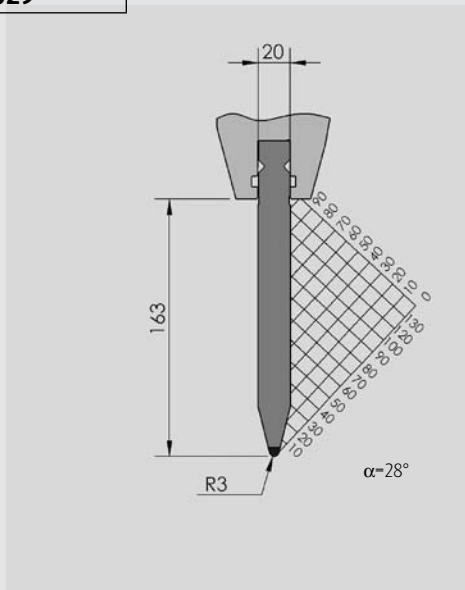

**BIU-026**

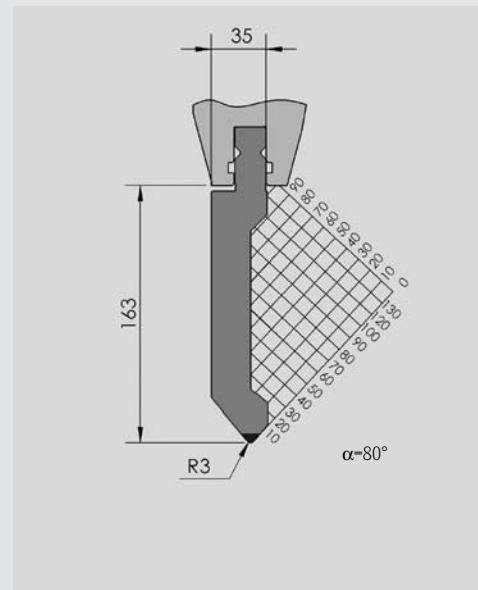

**BIU-025**

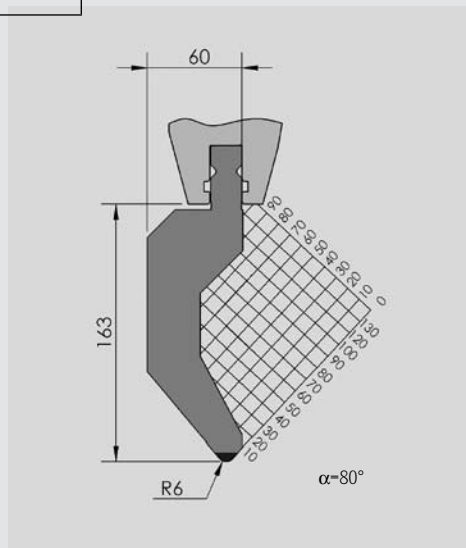

TYPE	LENGTH	WEIGHT KG	MAX LOAD	PRICE
BIU-029/1	515 mm*	15.6	160 T/Mtr.	
BIU-029/2	550 mm - sectioned	16.7		
BIU-029/3	200 mm - sectioned	6.1		
BIU-029/6	200 mm	6.1		
BIU-026/1	515 mm*	19.6	140 T/Mtr.	
BIU-026/2	550 mm - sectioned	20.9		
BIU-026/3	200 mm - sectioned	7.6		
BIU-026/6	200 mm	7.6		
BIU-025/1	515 mm*	27.7	130 T/Mtr.	
BIU-025/2	550 mm - sectioned	29.6		
BIU-025/3	200 mm - sectioned	10.8		
BIU-025/6	200 mm	10.8		

\* provided with fixed safety pins (see page 20/21).

**BIU-003**

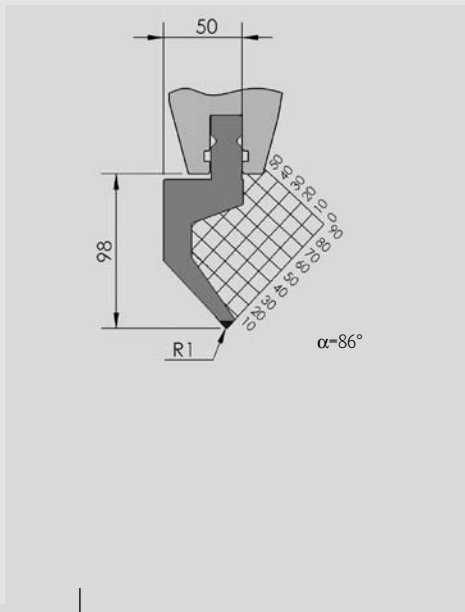

**BIU-013**

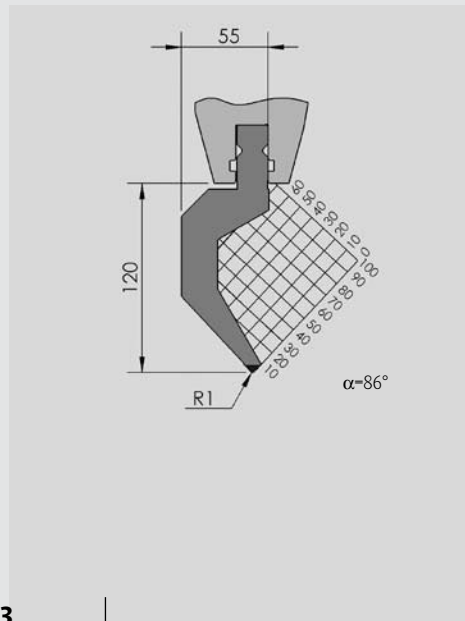

**BIU-023**

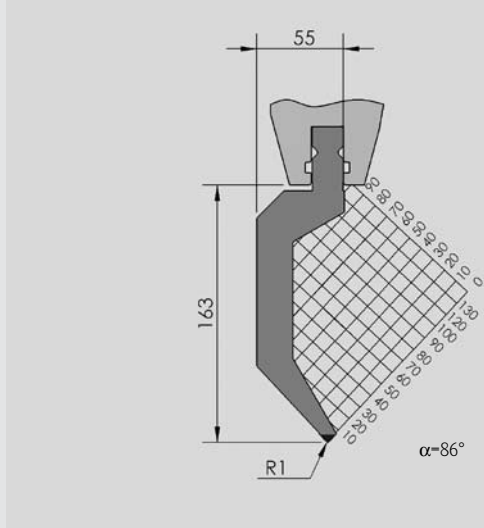

**BIU-033**

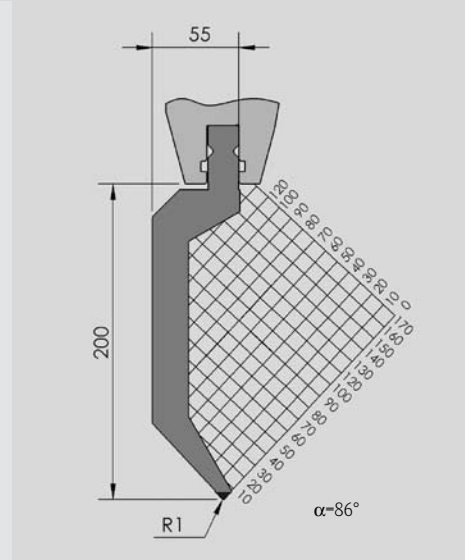

TYPE	LENGTH	WEIGHT		MAX LOAD	PRICE	
			KG			
BIU-003/1	515 mm		12.4	65 T/Mtr.		
BIU-003/2	550 mm - sectioned		13.2			
BIU-003/3	200 mm - sectioned		4.8			
BIU-003/6	200 mm		4.8			
BIU-013/1	515 mm*		15.5		65 T/Mtr.	
BIU-013/2	550 mm - sectioned		16.5			
BIU-013/3	200 mm - sectioned		6.0			
BIU-013/6	200 mm		6.0			
BIU-023/1	515 mm*		19.6	65 T/Mtr.		
BIU-023/2	550 mm - sectioned		20.9			
BIU-023/3	200 mm - sectioned		7.6			
BIU-023/6	200 mm		7.6			
BIU-033/1	515 mm*		23.1	50 T/Mtr.		
BIU-033/2	550 mm - sectioned		24.6			
BIU-033/3	200 mm - sectioned		9.0			
BIU-033/6	200 mm		9.0			

\* provided with fixed safety pins (see page 20/21).

**BIU-015**

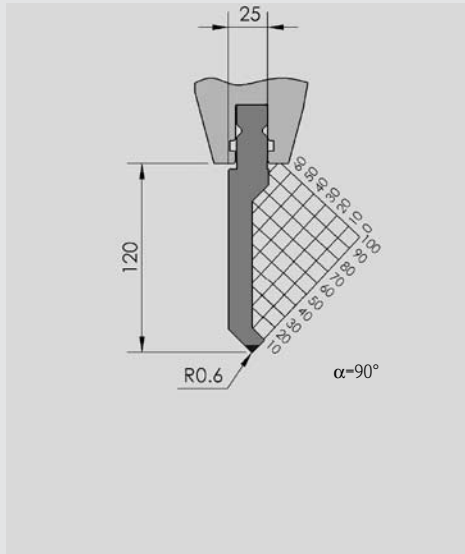

**BIU-035**

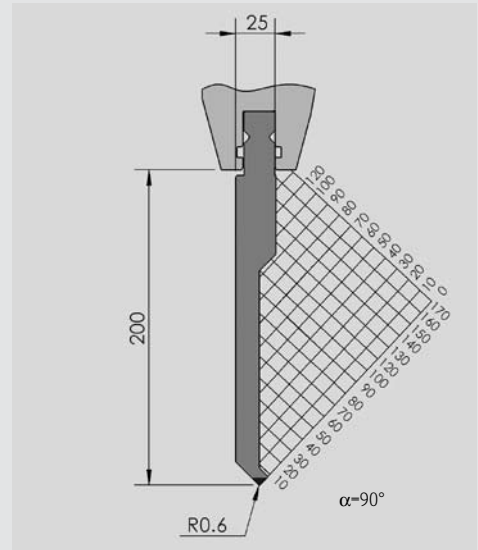

**BIU-016**

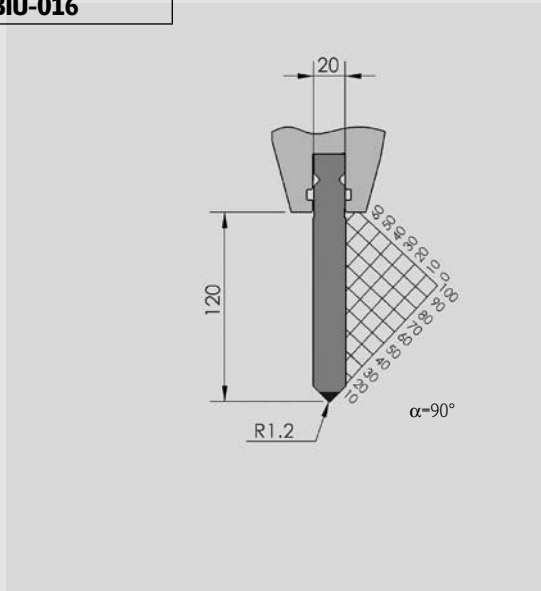

**BIU-036**

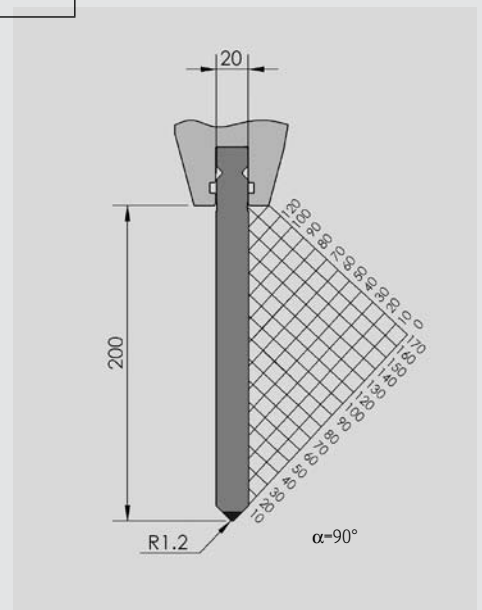

TYPE	LENGTH	WEIGHT KG	MAX LOAD	PRICE	
BIU-015/1	515 mm	11.0	60 T/Mtr.		
BIU-015/2	550 mm - sectioned	11.7			
BIU-015/3	200 mm - sectioned	4.3			
BIU-015/6	200 mm	4.3			
BIU-035/1	515 mm*	174		60 T/Mtr.	
BIU-035/2	550 mm - sectioned	18.5			
BIU-035/3	200 mm - sectioned	6.7			
BIU-035/6	200 mm	6.7			
BIU-016/1	515 mm	12.4	100 T/Mtr.		
BIU-016/2	550 mm - sectioned	13.3			
BIU-016/3	200 mm - sectioned	4.8			
BIU-016/6	200 mm	4.8			
BIU-036/1	515 m*	190	100 T/Mtr.		
BIU-036/2	550 mm - sectioned	20.3			
BIU-036/3	200 mm - sectioned	74			
BIU-036/6	200 mm	74			

\* provided with fixed safety pins (see page 20/21).



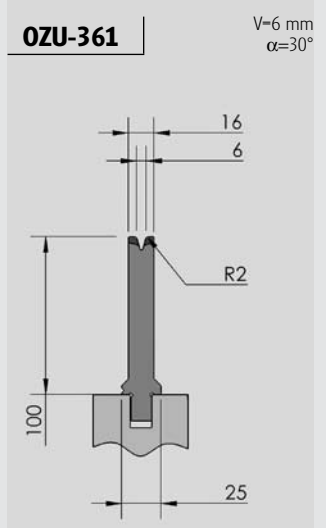
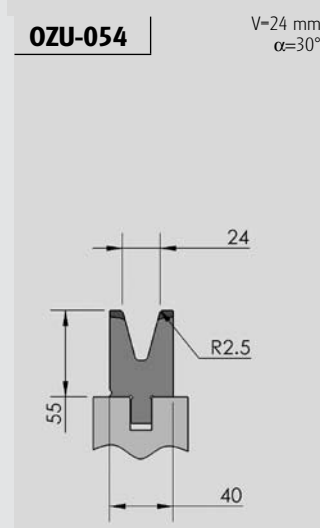
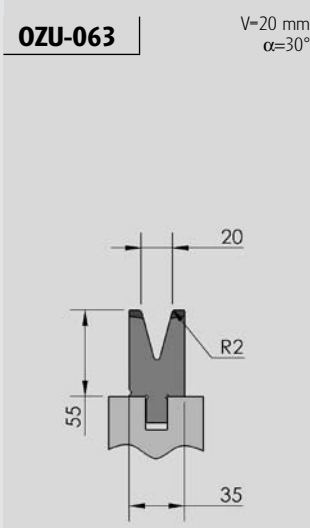
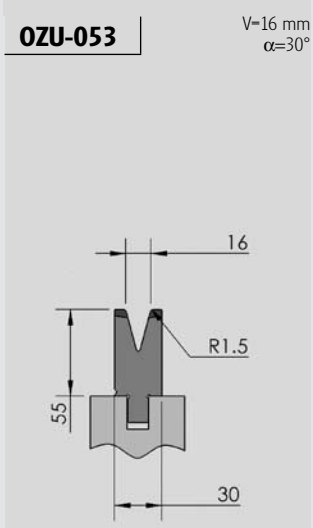
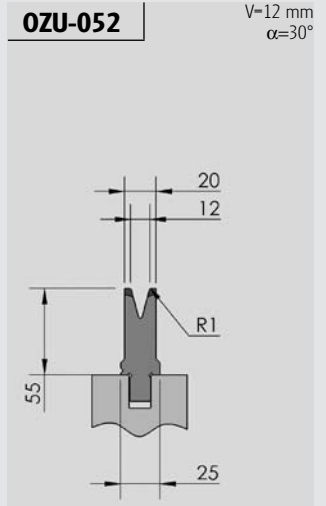
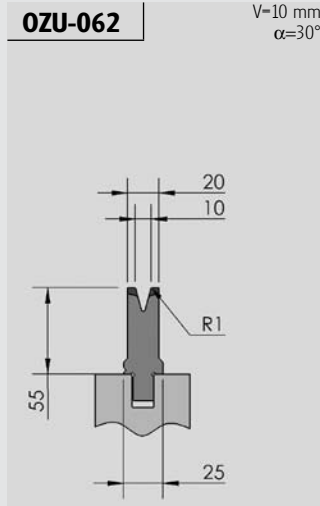
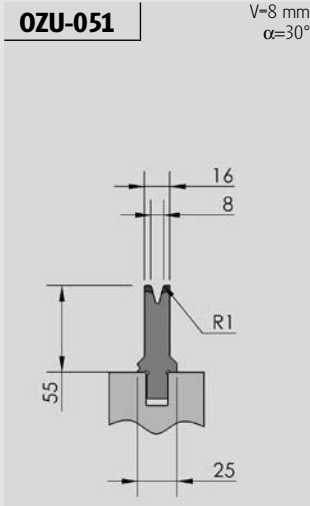
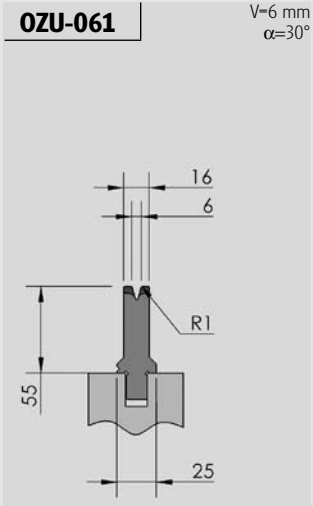

TYPE	LENGTH	WEIGHT	MAX LOAD	PRICE
		KG		
OZU-061/1	515 mm	4.9		
OZU-061/2	550 mm - sectioned	5.2	80 T/Mtr.	
OZU-061/3	200 mm - sectioned	1.9	$\alpha=90^\circ$	
OZU-061/6	200 mm	1.9		
OZU-051/1	515 mm	4.9		
OZU-051/2	550 mm - sectioned	5.2	80 T/Mtr.	
OZU-051/3	200 mm - sectioned	1.9	$\alpha=90^\circ$	
OZU-051/6	200 mm	1.9		
OZU-062/1	515 mm	5.4		
OZU-062/2	550 mm - sectioned	5.8	80 T/Mtr.	
OZU-062/3	200 mm - sectioned	2.1	$\alpha=90^\circ$	
OZU-062/6	200 mm	2.1		
OZU-052/1	515 mm	5.2		
OZU-052/2	550 mm - sectioned	5.5	80 T/Mtr.	
OZU-052/3	200 mm - sectioned	2.0	$\alpha=90^\circ$	
OZU-052/6	200 mm	2.0		

TYPE	LENGTH	WEIGHT	MAX LOAD	PRICE
		KG		
OZU-053/1	515 mm	7.0		
OZU-053/2	550 mm - sectioned	7.4	80 T/Mtr.	
OZU-053/3	200 mm - sectioned	2.7	$\alpha=90^\circ$	
OZU-053/6	200 mm	2.7		
OZU-063/1	515 mm	7.7		
OZU-063/2	550 mm - sectioned	8.3	80 T/Mtr.	
OZU-063/3	200 mm - sectioned	3.0	$\alpha=90^\circ$	
OZU-063/6	200 mm	3.0		
OZU-054/1	515 mm	8.2		
OZU-054/2	550 mm - sectioned	8.8	80 T/Mtr.	
OZU-054/3	200 mm - sectioned	3.2	$\alpha=90^\circ$	
OZU-054/6	200 mm	3.2		
OZU-361/1	515 mm	7.8		
OZU-361/2	550 mm - sectioned	8.4	80 T/Mtr.	
OZU-361/3	200 mm - sectioned	3.0	$\alpha=90^\circ$	
OZU-361/6	200 mm	3.0		



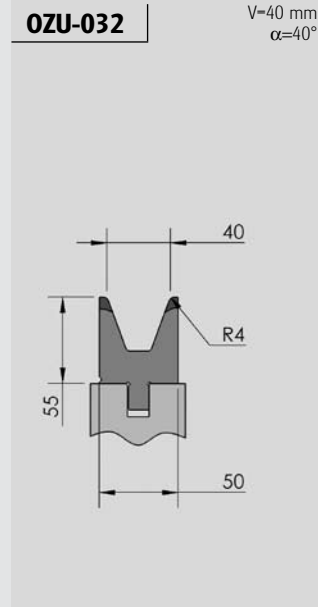
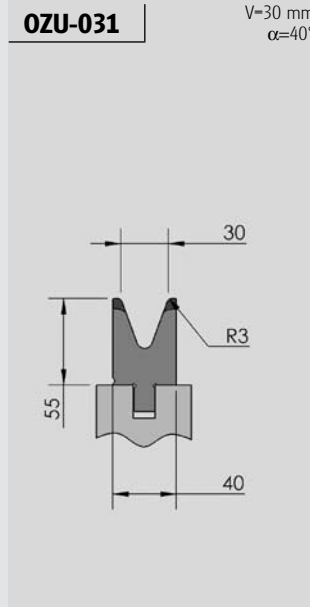
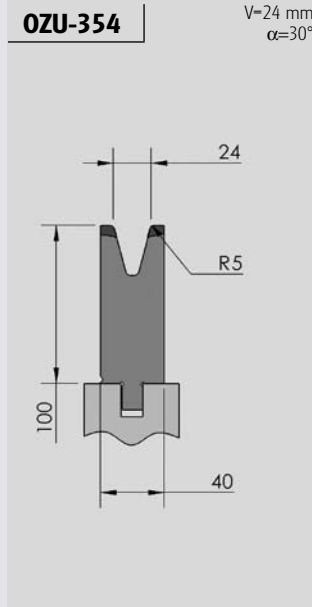
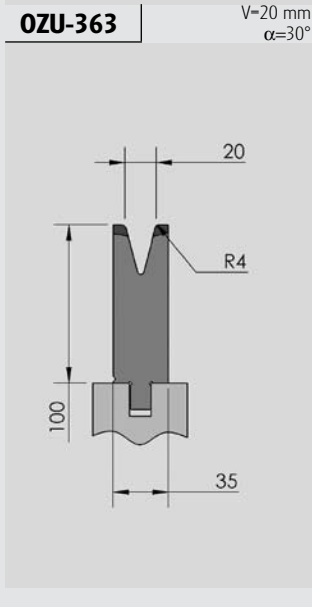
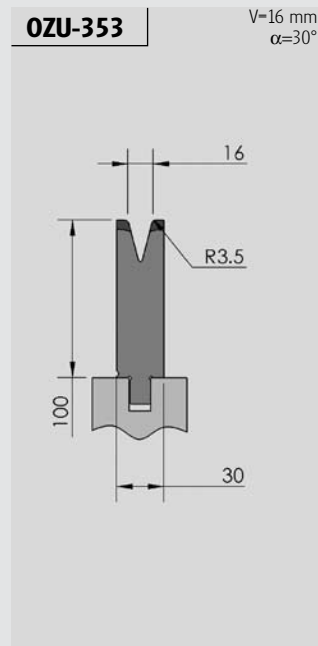
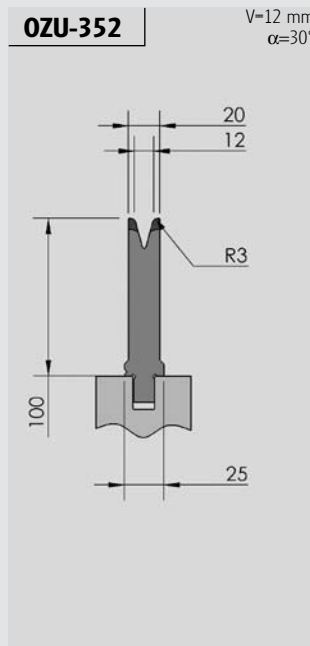
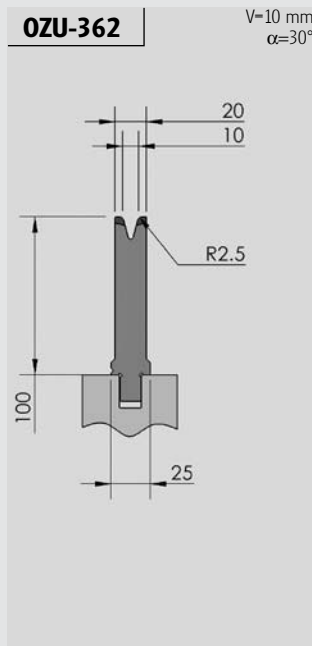
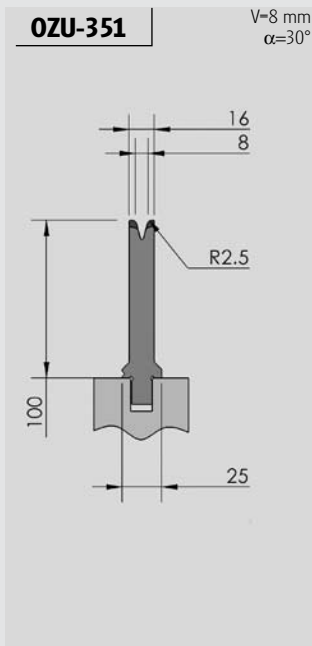

TYPE	LENGTH	WEIGHT			MAX LOAD	PRICE
		KG				
OZU-351/1	515 mm		7.7			
OZU-351/2	550 mm - sectioned		8.3		80 T/Mtr.	
OZU-351/3	200 mm - sectioned		3.0		$\alpha=90^\circ$	
OZU-351/6	200 mm		3.0			
OZU-362/1	515 mm		9.1			
OZU-362/2	550 mm - sectioned		9.7		80 T/Mtr.	
OZU-362/3	200 mm - sectioned		3.5		$\alpha=90^\circ$	
OZU-362/6	200 mm		3.5			
OZU-352/1	515 mm		9.0			
OZU-352/2	550 mm - sectioned		9.6		80 T/Mtr.	
OZU-352/3	200 mm - sectioned		3.5		$\alpha=90^\circ$	
OZU-352/6	200 mm		3.5			
OZU-353/1	515 mm		12.5			
OZU-353/2	550 mm - sectioned		13.3		80 T/Mtr.	
OZU-353/3	200 mm - sectioned		4.8		$\alpha=90^\circ$	
OZU-353/6	200 mm		4.8			

TYPE	LENGTH	WEIGHT			MAX LOAD	PRICE
		KG				
OZU-363/1	515 mm		14.0			
OZU-363/2	550 mm - sectioned		15.0		80 T/Mtr.	
OZU-363/3	200 mm - sectioned		5.4		$\alpha=90^\circ$	
OZU-363/6	200 mm		5.4			
OZU-354/1	515 mm		15.5			
OZU-354/2	550 mm - sectioned		16.6		80 T/Mtr.	
OZU-354/3	200 mm - sectioned		6.0		$\alpha=90^\circ$	
OZU-354/6	200 mm		6.0			
OZU-031/1	515 mm		7.7			
OZU-031/2	550 mm - sectioned		8.3		70 T/Mtr.	
OZU-031/3	200 mm - sectioned		3.0		$\alpha=90^\circ$	
OZU-031/6	200 mm		3.0			
OZU-032/1	515 mm		8.8			
OZU-032/2	550 mm - sectioned		9.4		80 T/Mtr.	
OZU-032/3	200 mm - sectioned		3.4		$\alpha=90^\circ$	
OZU-032/6	200 mm		3.4			

**OZU-328**

V=30 mm  
 $\alpha=40^\circ$

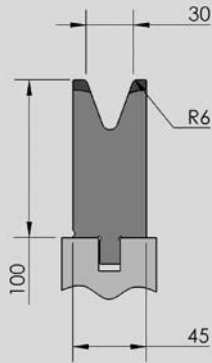

**OZU-329**

V=40 mm  
 $\alpha=40^\circ$

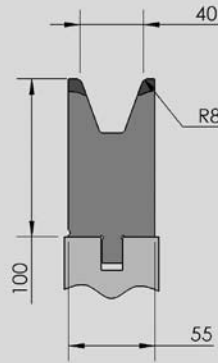

**OZU-016**

V=60 mm  
 $\alpha=60^\circ$

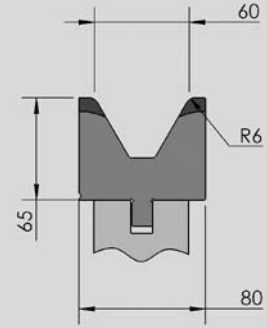

**OZU-327**

V=60 mm  
 $\alpha=60^\circ$

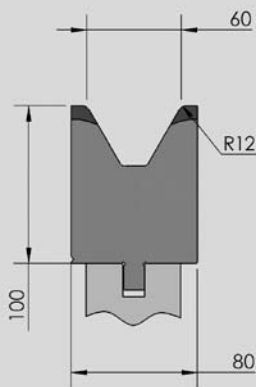

**OZU-070**

V=120 mm  
 $\alpha=70^\circ$

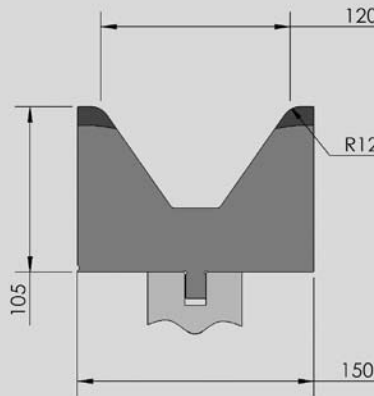

**OZU-071**

V=160 mm  
 $\alpha=70^\circ$

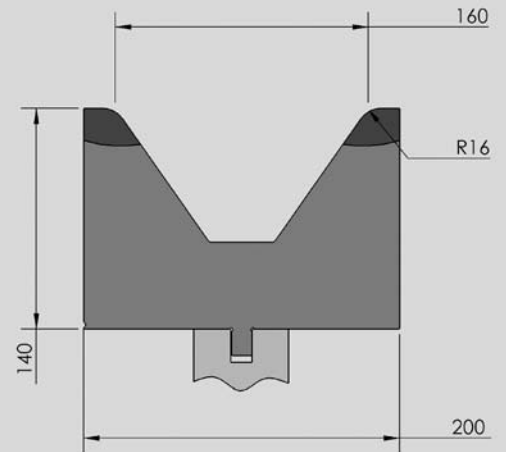

TYPE	LENGTH	WEIGHT KG	MAX LOAD	PRICE
OZU-328/1	515 mm	170		
OZU-328/2	550 mm - sectioned	18.2	100 T/Mtr.	
OZU-328/3	200 mm - sectioned	6.6	$\alpha=90^\circ$	
OZU-328/6	200 mm	6.6		
OZU-329/1	515 mm	279		
OZU-329/2	550 mm - sectioned	29.8	125 T/Mtr.	
OZU-329/3	200 mm - sectioned	10.8	$\alpha=90^\circ$	
OZU-329/6	200 mm	10.8		
OZU-016/1	515 mm	16.5		
OZU-016/2	550 mm - sectioned	176	125 T/Mtr.	
OZU-016/3	200 mm - sectioned	6.4	$\alpha=90^\circ$	
OZU-016/6	200 mm	6.4		

TYPE	LENGTH	WEIGHT KG	MAX LOAD	PRICE
OZU-327/1	515 mm	279		
OZU-327/2	550 mm - sectioned	29.8	125 T/Mtr.	
OZU-327/3	200 mm - sectioned	10.8	$\alpha=90^\circ$	
OZU-327/6	200 mm	10.8		
OZU-070/1	515 mm	45.5		
OZU-070/6	200 mm	177	250 T/Mtr.	
			$\alpha=90^\circ$	
OZU-071/1	515 mm	79.2		
OZU-071/6	200 mm	30.8	250 T/Mtr.	
			$\alpha=90^\circ$	

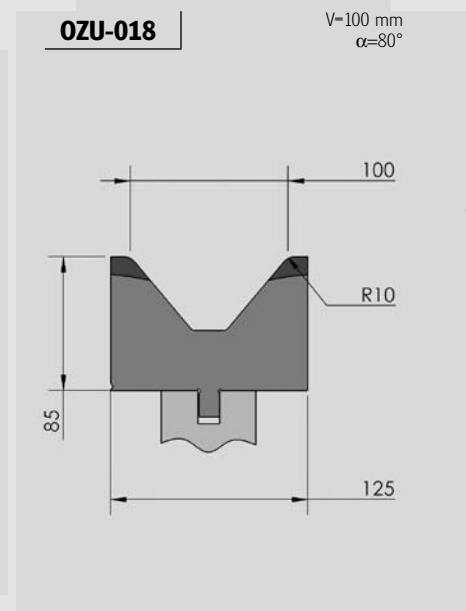
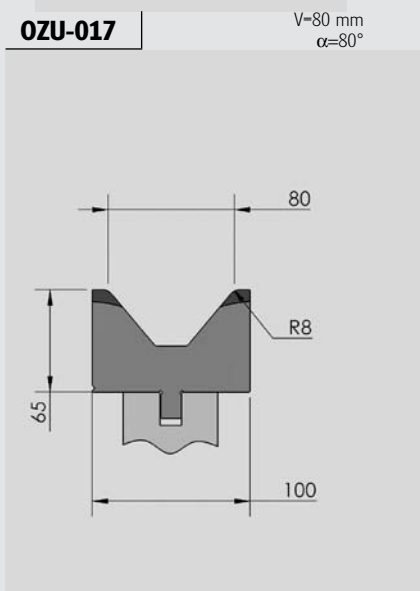
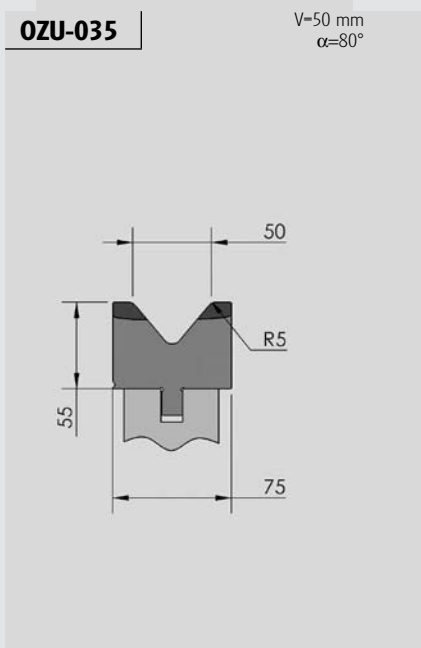
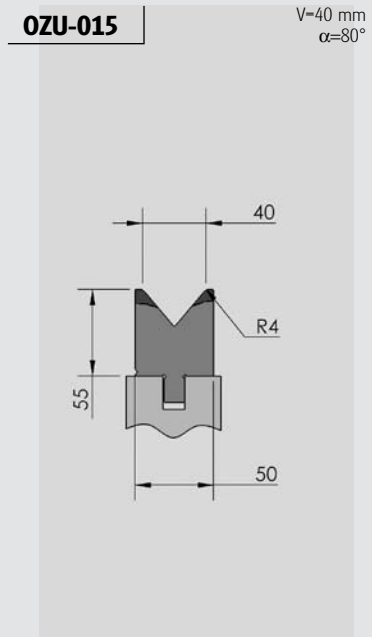
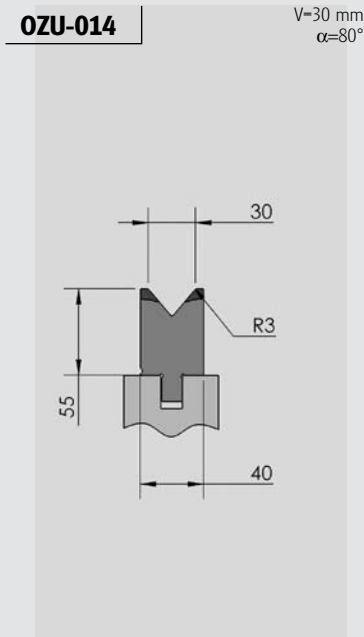
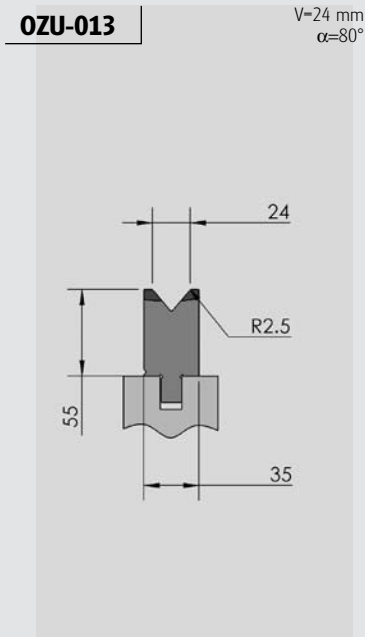

TYPE	LENGTH	WEIGHT KG	MAX LOAD	PRICE
OZU-013/1	515 mm	8.2		
OZU-013/2	550 mm - sectioned	8.8	125 T/Mtr.	
OZU-013/3	200 mm - sectioned	3.2	$\alpha=90^\circ$	
OZU-013/6	200 mm	3.2		
OZU-014/1	515 mm	8.8		
OZU-014/2	550 mm - sectioned	9.4	125 T/Mtr.	
OZU-014/3	200 mm - sectioned	3.4	$\alpha=90^\circ$	
OZU-014/6	200 mm	3.4		
OZU-015/1	515 mm	10.8		
OZU-015/2	550 mm - sectioned	11.6	125 T/Mtr.	
OZU-015/3	200 mm - sectioned	4.2	$\alpha=90^\circ$	
OZU-015/6	200 mm	4.2		

TYPE	LENGTH	WEIGHT KG	MAX LOAD	PRICE
OZU-035/1	515 mm	14.9		
OZU-035/2	550 mm - sectioned	16.0	150 T/Mtr.	
OZU-035/3	200 mm - sectioned	5.8	$\alpha=90^\circ$	
OZU-035/6	200 mm	5.8		
OZU-017/1	515 mm	19.8		
OZU-017/6	200 mm	7.7	150 T/Mtr.	
			$\alpha=90^\circ$	
OZU-018/1	515 mm	32.2		
OZU-018/6	200 mm	12.5	150 T/Mtr.	
			$\alpha=90^\circ$	

**OZU-313**

V=24 mm  
 $\alpha=80^\circ$

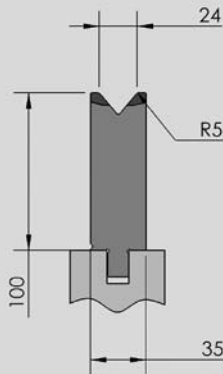

**OZU-324**

V=30 mm  
 $\alpha=80^\circ$

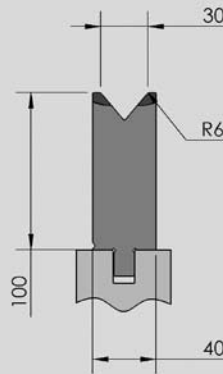

**OZU-325**

V=40 mm  
 $\alpha=80^\circ$

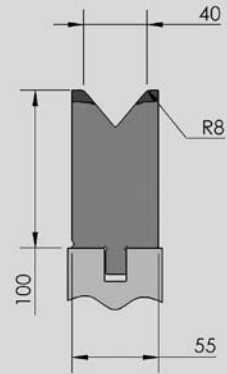

**OZU-326**

V=50 mm  
 $\alpha=80^\circ$

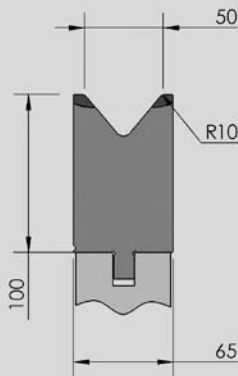

**OZU-317**

V=80 mm  
 $\alpha=80^\circ$

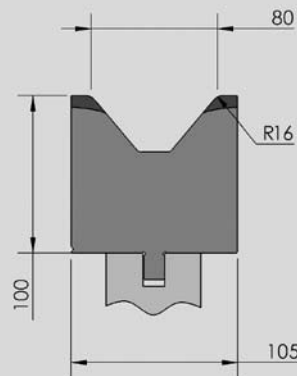

**OZU-318**

V=100 mm  
 $\alpha=80^\circ$

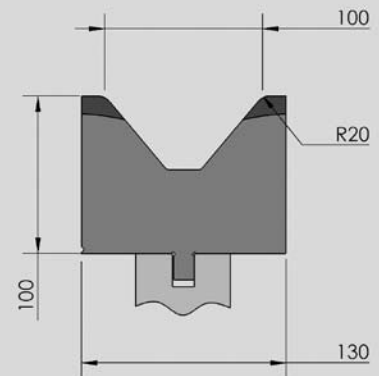

TYPE	LENGTH	WEIGHT	MAX LOAD	PRICE
		KG		
OZU-313/1	515 mm	13.6		
OZU-313/2	550 mm - sectioned	14.6	125 T/Mtr.	
OZU-313/3	200 mm - sectioned	5.3	$\alpha=90^\circ$	
OZU-313/6	200 mm	5.3		
OZU-324/1	515 mm	16.5		
OZU-324/2	550 mm - sectioned	17.7	125 T/Mtr.	
OZU-324/3	200 mm - sectioned	6.4	$\alpha=90^\circ$	
OZU-324/6	200 mm	6.4		
OZU-325/1	515 mm	21.6		
OZU-325/2	550 mm - sectioned	23.0	125 T/Mtr.	
OZU-325/3	200 mm - sectioned	8.4	$\alpha=90^\circ$	
OZU-325/6	200 mm	8.4		

TYPE	LENGTH	WEIGHT	MAX LOAD	PRICE
		KG		
OZU-326/1	515 mm	24.6		
OZU-326/2	550 mm - sectioned	26.3	150 T/Mtr.	
OZU-326/3	200 mm - sectioned	9.6	$\alpha=90^\circ$	
OZU-326/6	200 mm	9.6		
OZU-317/1	515 mm	36.4		
OZU-317/6	200 mm	14.1	150 T/Mtr.	
			$\alpha=90^\circ$	
OZU-318/1	515 mm	42.0		
OZU-318/6	200 mm	16.3	150 T/Mtr.	
			$\alpha=90^\circ$	

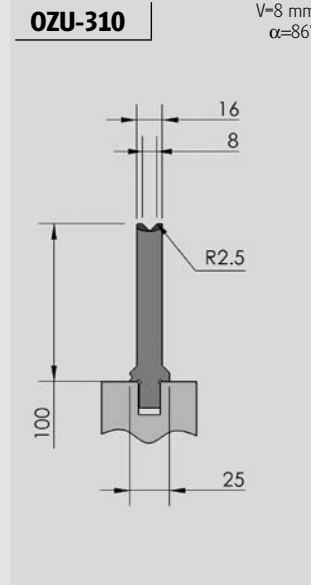
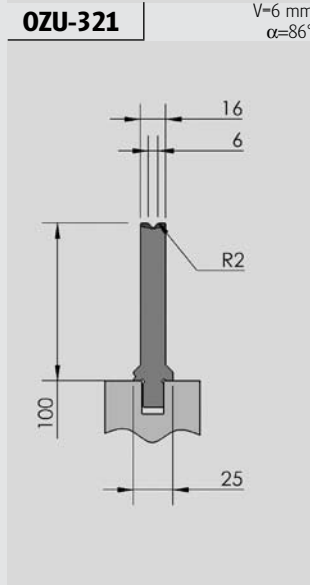
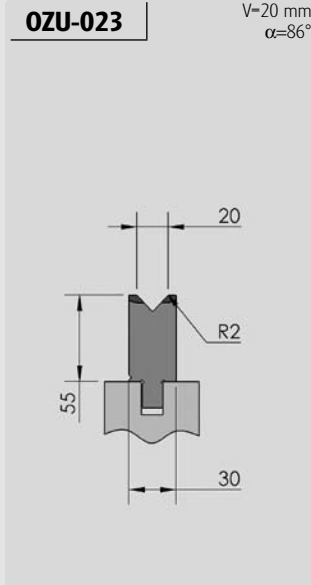
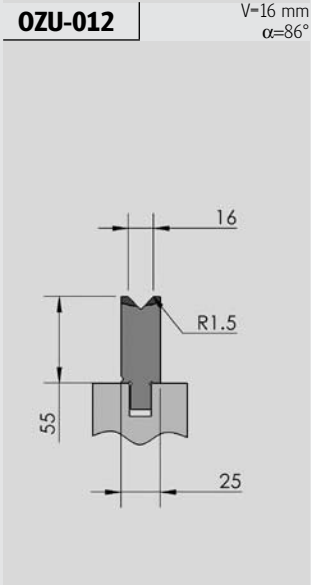
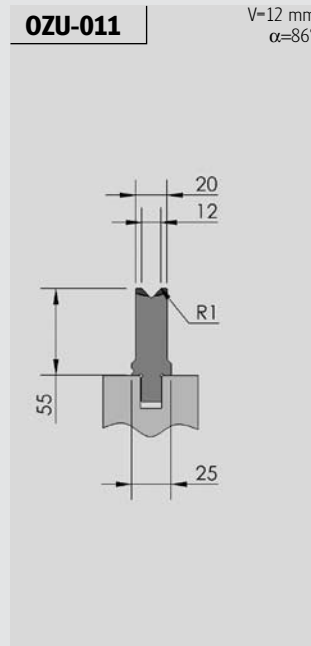
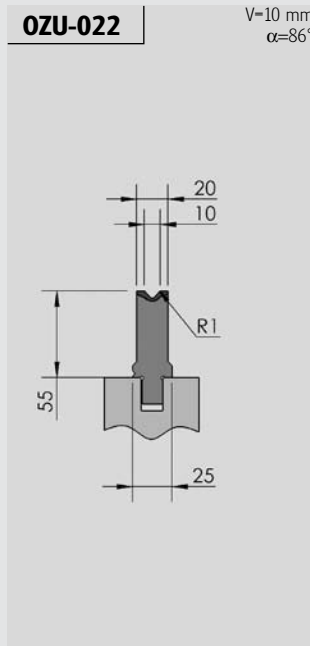
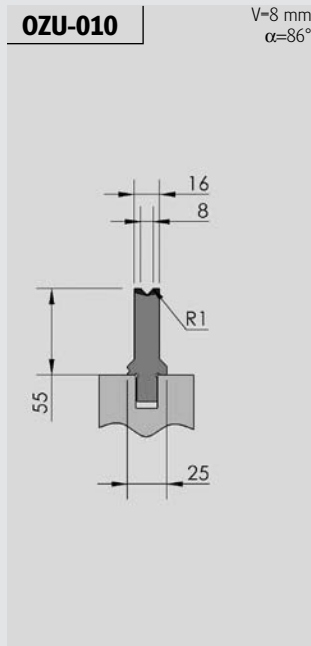
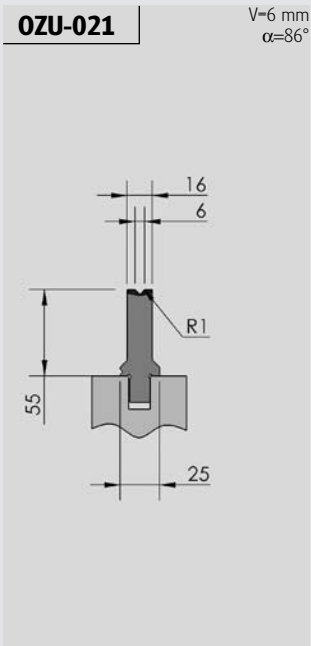

TYPE	LENGTH	WEIGHT			MAX LOAD	PRICE
		KG				
OZU-021/1	515 mm	4.9			120 T/Mtr.	
OZU-021/2	550 mm - sectioned	5.2				
OZU-021/3	200 mm - sectioned	1.9				
OZU-021/6	200 mm	1.9				
OZU-010/1	515 mm	4.9			120 T/Mtr.	
OZU-010/2	550 mm - sectioned	5.2				
OZU-010/3	200 mm - sectioned	1.9				
OZU-010/6	200 mm	1.9				
OZU-022/1	515 mm	5.7			120 T/Mtr.	
OZU-022/2	550 mm - sectioned	6.1				
OZU-022/3	200 mm - sectioned	2.2				
OZU-022/6	200 mm	2.2				
OZU-011/1	515 mm	5.7			120 T/Mtr.	
OZU-011/2	550 mm - sectioned	6.1				
OZU-011/3	200 mm - sectioned	2.2				
OZU-011/6	200 mm	2.2				

TYPE	LENGTH	WEIGHT			MAX LOAD	PRICE
		KG				
OZU-012/1	515 mm	6.7			120 T/Mtr.	
OZU-012/2	550 mm - sectioned	7.2				
OZU-012/3	200 mm - sectioned	2.6				
OZU-012/6	200 mm	2.6				
OZU-023/1	515 mm	7.7			120 T/Mtr.	
OZU-023/2	550 mm - sectioned	8.3				
OZU-023/3	200 mm - sectioned	3.0				
OZU-023/6	200 mm	3.0				
OZU-321/1	515 mm	7.8			120 T/Mtr.	
OZU-321/2	550 mm - sectioned	8.3				
OZU-321/3	200 mm - sectioned	3.0				
OZU-321/6	200 mm	3.0				
OZU-310/1	515 mm	7.8			120 T/Mtr.	
OZU-310/2	550 mm - sectioned	8.3				
OZU-310/3	200 mm - sectioned	3.0				
OZU-310/6	200 mm	3.0				

**TOOLING**

**NEW STANDARD** PREMIUM

**OZU-322**

V=10 mm  
 $\alpha=86^\circ$

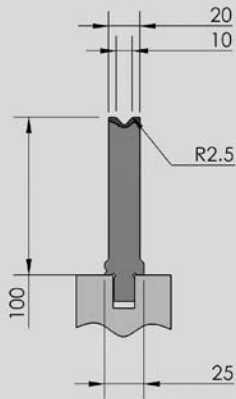

**OZU-311**

V=12 mm  
 $\alpha=86^\circ$

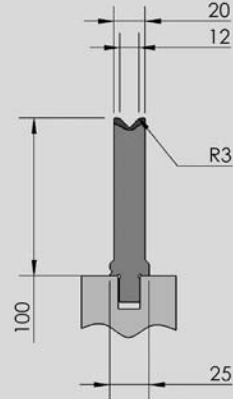

**OZU-312**

V=16 mm  
 $\alpha=86^\circ$

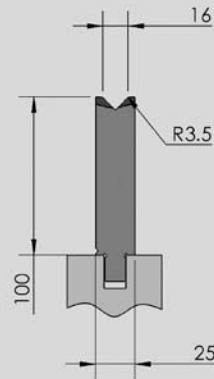

**OZU-323**

V=20 mm  
 $\alpha=86^\circ$

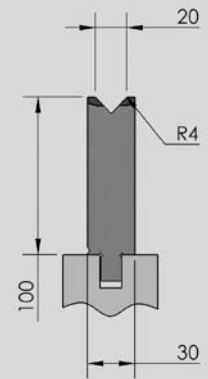

**OZU-041**

V=6 mm  
 $\alpha=90^\circ$

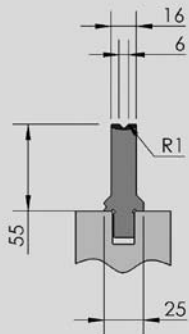

**OZU-042**

V=8 mm  
 $\alpha=90^\circ$

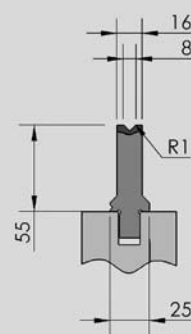

**OZU-043**

V=10 mm  
 $\alpha=90^\circ$

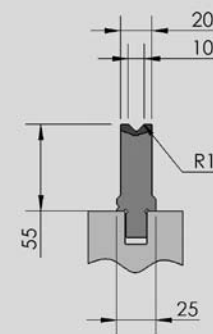

**OZU-044**

V=12 mm  
 $\alpha=90^\circ$

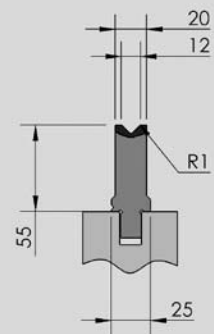

TYPE	LENGTH	WEIGHT	MAX LOAD	PRICE
		KG		
OZU-322/1	515 mm	9.2	120 T/Mtr.	
OZU-322/2	550 mm - sectioned	9.8		
OZU-322/3	200 mm - sectioned	3.6		
OZU-322/6	200 mm	3.6		
OZU-311/1	515 mm	9.2	120 T/Mtr.	
OZU-311/2	550 mm - sectioned	9.8		
OZU-311/3	200 mm - sectioned	3.6		
OZU-311/6	200 mm	3.6		
OZU-312/1	515 mm	9.9	120 T/Mtr.	
OZU-312/2	550 mm - sectioned	10.6		
OZU-312/3	200 mm - sectioned	3.9		
OZU-312/6	200 mm	3.9		
OZU-323/1	515 mm	12.8	120 T/Mtr.	
OZU-323/2	550 mm - sectioned	13.7		
OZU-323/3	200 mm - sectioned	5.0		
OZU-323/6	200 mm	5.0		

TYPE	LENGTH	WEIGHT	MAX LOAD	PRICE
		KG		
OZU-041/1	515 mm	4.9	120 T/Mtr.	
OZU-041/2	550 mm - sectioned	5.2		
OZU-041/3	200 mm - sectioned	1.9		
OZU-041/6	200 mm	1.9		
OZU-042/1	515 mm	4.9	120 T/Mtr.	
OZU-042/2	550 mm - sectioned	5.2		
OZU-042/3	200 mm - sectioned	1.9		
OZU-042/6	200 mm	1.9		
OZU-043/1	515 mm	5.7	120 T/Mtr.	
OZU-043/2	550 mm - sectioned	6.1		
OZU-043/3	200 mm - sectioned	2.2		
OZU-043/6	200 mm	2.2		
OZU-044/1	515 mm	5.7	120 T/Mtr.	
OZU-044/2	550 mm - sectioned	6.1		
OZU-044/3	200 mm - sectioned	2.2		
OZU-044/6	200 mm	2.2		

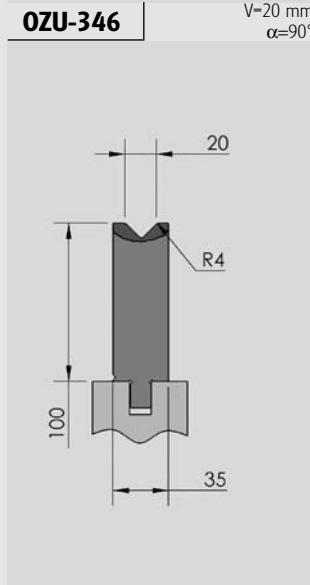
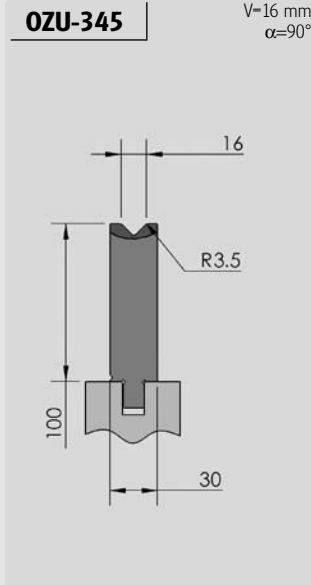
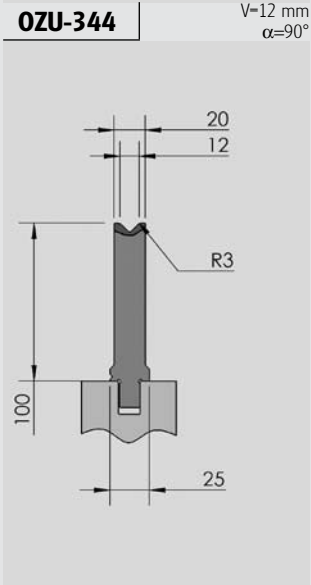
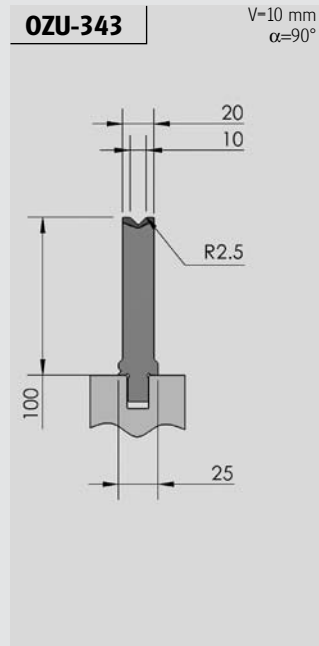
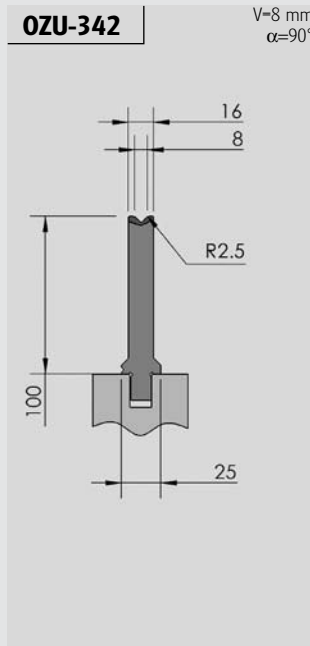
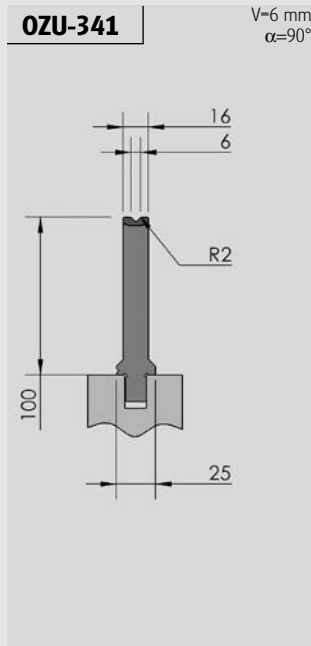
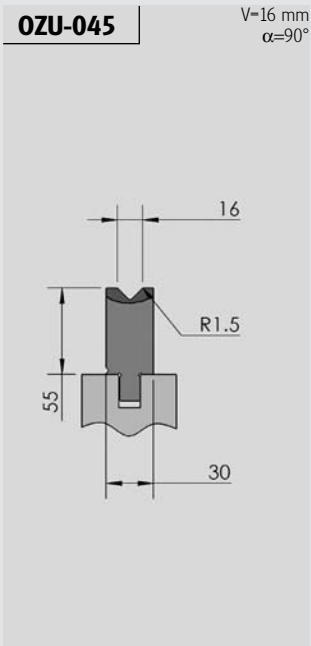

TYPE	LENGTH	120 T/Mtr.		
		WEIGHT	MAX LOAD	PRICE
KG				
OZU-045/1	515 mm	7.7		
OZU-045/2	550 mm - sectioned	8.3		
OZU-045/3	200 mm - sectioned	3.0		
OZU-045/6	200 mm	3.0		
OZU-341/1	515 mm	7.8		
OZU-341/2	550 mm - sectioned	8.3		
OZU-341/3	200 mm - sectioned	3.0		
OZU-341/6	200 mm	3.0		
OZU-342/1	515 mm	7.8		
OZU-342/2	550 mm - sectioned	8.3		
OZU-342/3	200 mm - sectioned	3.0		
OZU-342/6	200 mm	3.0		
OZU-343/1	515 mm	9.2		
OZU-343/2	550 mm - sectioned	9.8		
OZU-343/3	200 mm - sectioned	3.6		
OZU-323/6	200 mm	3.6		

TYPE	LENGTH	120 T/Mtr.		
		WEIGHT	MAX LOAD	PRICE
KG				
OZU-344/1	515 mm	9.2		
OZU-344/2	550 mm - sectioned	9.8		
OZU-344/3	200 mm - sectioned	3.6		
OZU-344/6	200 mm	3.6		
OZU-345/1	515 mm	12.7		
OZU-345/2	550 mm - sectioned	13.5		
OZU-345/3	200 mm - sectioned	4.9		
OZU-345/6	200 mm	4.9		
OZU-346/1	515 mm	14.8		
OZU-346/2	550 mm - sectioned	15.8		
OZU-346/3	200 mm - sectioned	5.7		
OZU-346/6	200 mm	5.7		

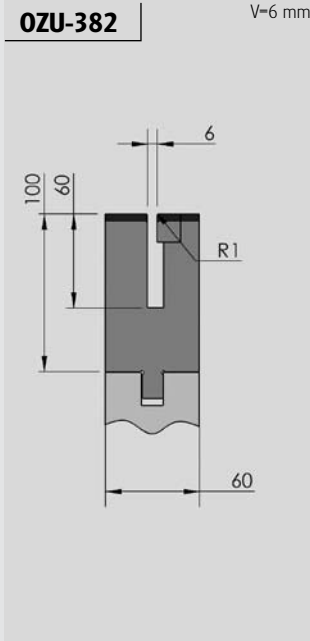
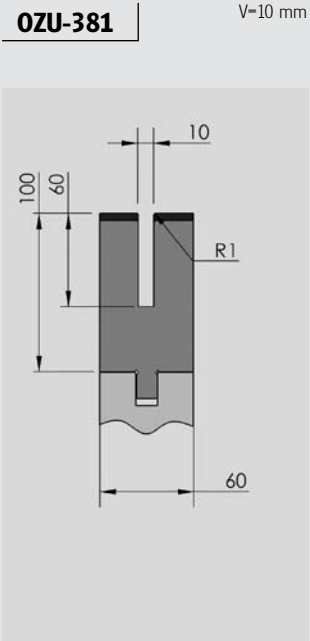
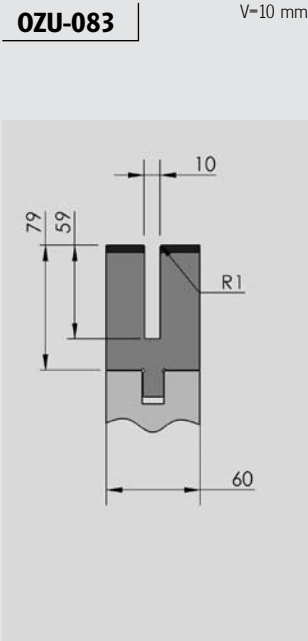
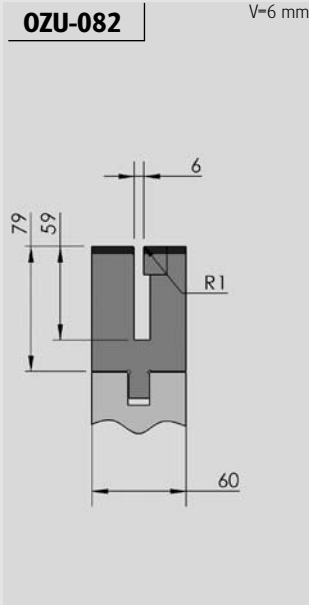

TYPE	LENGTH	WEIGHT	MAX LOAD	PRICE
		<b>KG</b>		
OZU-082/1	515 mm	18.5		
OZU-082/6	200 mm	7.2	50 T/Mtr.	$\alpha=90^\circ$
OZU-083/1	515 mm	18.0		
OZU-083/6	200 mm	7.0	50 T/Mtr.	$\alpha=90^\circ$
OZU-381/1	515 mm	23.0		
OZU-381/6	200 mm	8.9	50 T/Mtr.	$\alpha=90^\circ$
OZU-382/1	515 mm	23.2		
OZU-382/6	200 mm	9.0	50 T/Mtr.	$\alpha=90^\circ$

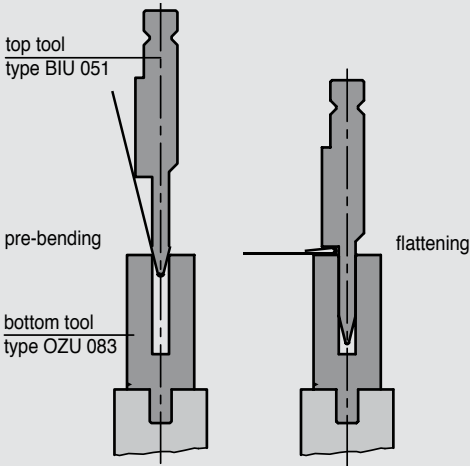



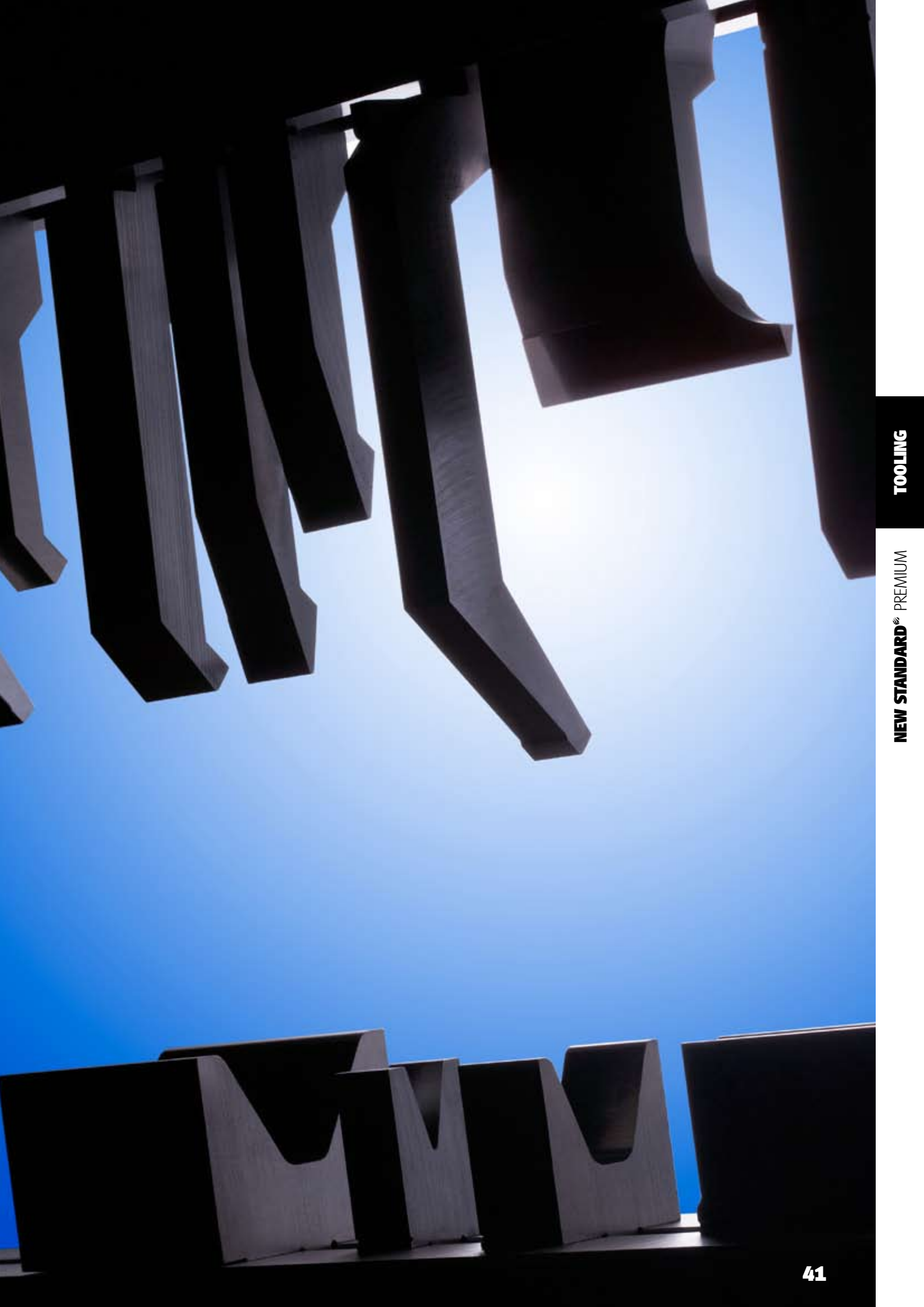

**BIU-401**

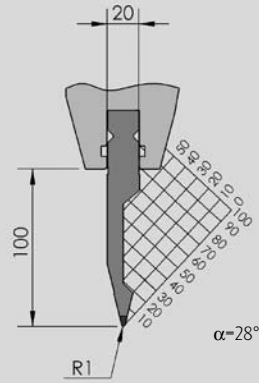

**BIU-403**

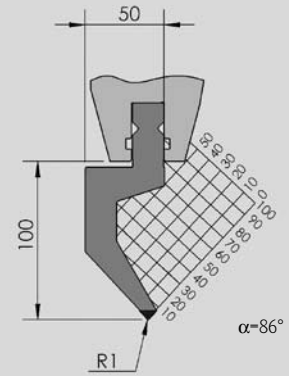

**BIU-404**

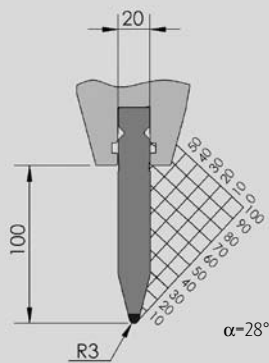

TYPE	LENGTH	WEIGHT	MAX LOAD	PRICE
		KG		
BIU-401/1	515 mm	73	65 T/Mtr.	.....
BIU-401/10	475 mm - sectioned	6.7		
BIU-401/11	200 mm - sectioned	2.8		
BIU-403/1	515 mm	12.3	60 T/Mtr.	.....
BIU-403/10	475 mm - sectioned	11.4		
BIU-403/11	200 mm - sectioned	4.8		
BIU-404/1	515 mm	10.1	100 T/Mtr.	.....
BIU-404/10	475 mm - sectioned	9.3		
BIU-404/11	200 mm - sectioned	3.9		

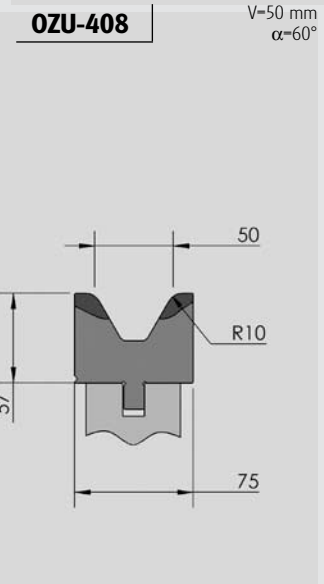
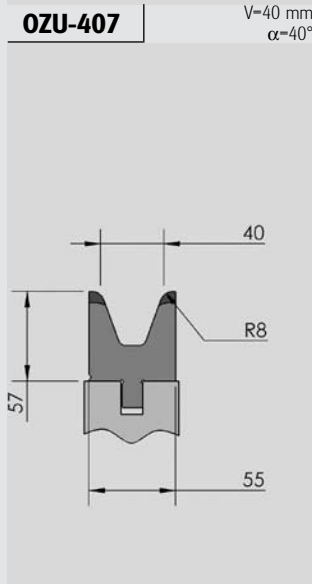
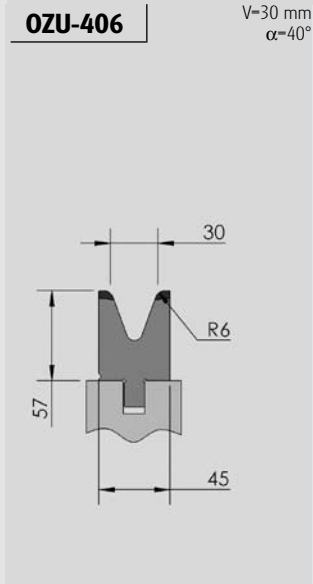
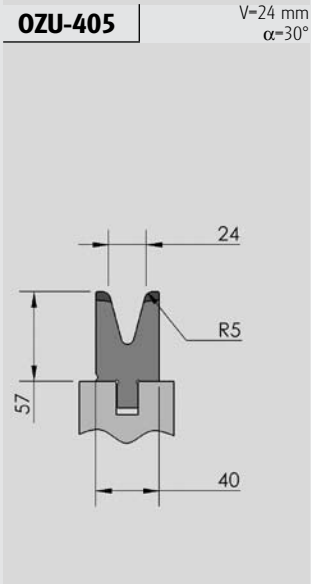
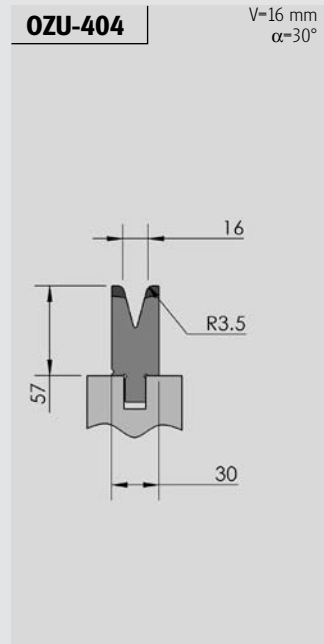
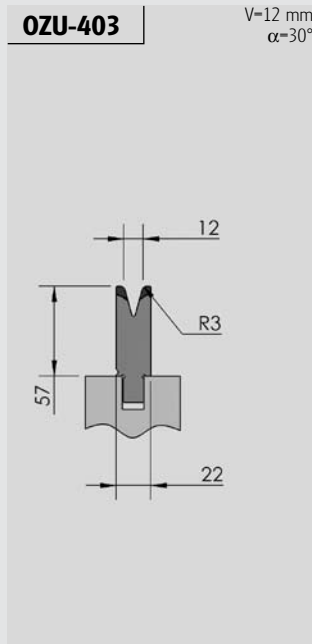
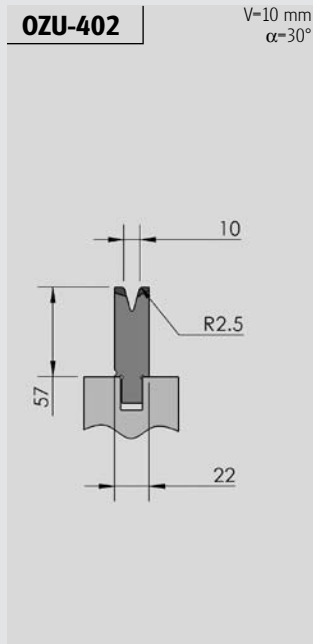
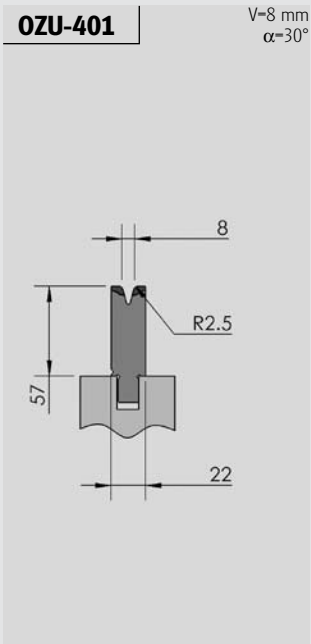

TYPE	LENGTH	WEIGHT	MAX LOAD	PRICE
		KG		
OZU-401/1	515 mm	5.7	60 T/Mtr. $\alpha=90^\circ$	-----
OZU-401/10	475 mm - sectioned	5.2		
OZU-401/3	200 mm - sectioned	2.2		
OZU-402/1	515 mm	5.6	60 T/Mtr. $\alpha=90^\circ$	-----
OZU-402/10	475 mm - sectioned	5.1		
OZU-402/3	200 mm - sectioned	2.2		
OZU-403/1	515 mm	5.4	60 T/Mtr. $\alpha=90^\circ$	-----
OZU-403/10	475 mm - sectioned	5.0		
OZU-403/3	200 mm - sectioned	2.1		
OZU-404/1	515 mm	6.8	60 T/Mtr. $\alpha=90^\circ$	-----
OZU-404/10	475 mm - sectioned	6.3		
OZU-404/3	200 mm - sectioned	2.7		

TYPE	LENGTH	WEIGHT	MAX LOAD	PRICE
		KG		
OZU-405/1	515 mm	8.1	60 T/Mtr. $\alpha=90^\circ$	-----
OZU-405/10	475 mm - sectioned	7.5		
OZU-405/3	200 mm - sectioned	3.2		
OZU-406/1	515 mm	8.9	70 T/Mtr. $\alpha=90^\circ$	-----
OZU-406/10	475 mm - sectioned	8.2		
OZU-406/3	200 mm - sectioned	3.5		
OZU-407/1	515 mm	9.7	80 T/Mtr. $\alpha=90^\circ$	-----
OZU-407/10	475 mm - sectioned	8.9		
OZU-407/3	200 mm - sectioned	3.8		
OZU-408/1	515 mm	14.2	100 T/Mtr. $\alpha=90^\circ$	-----
OZU-408/10	475 mm - sectioned	13.1		
OZU-408/3	200 mm - sectioned	5.5		

**TOOLING**

# MODIFIED TOP AND BOTTOM TOOLS (BMS, OMS)

We designed our New Standard tools with the utmost care. This allows you to cover a large number of applications with just a few universal tools. These universal tools are often available as standard in different working heights so you can make optimal use of the tool daylight and stroke length of your press brake.

**Special tooling**

Obviously, we acknowledge that there are also applications which require special tools. That is why our New Standard Premium tools are also available with modified bending radii (top tools) or with a step down relief on the front and/or back (bottom tools).

**BMS: Standard top tools with a modified bending radius**

Almost all of our top tools are available with a number of customized bending radii. The available radii with a given tool angle are listed in the table below. These radii are ground with the same precision as our standard top tools which guarantees exchangeability with subsequent deliveries. With a remaining hardening zone of approximately 2mm by means of CNC-Deephhardening, an optimal product life is guaranteed. Just like our standard tools, these are also provided with laser marking with all the tool specifications.

TOP TOOLS BMS WITH MODIFIED BENDING RADII				
Available bending radii	Angle of BIU top tools	Existing standard radius	Range of possible bending radii	
			Minimum	Maximum
0.40 mm				
0.50 mm	28°	1.00 mm	0.80 mm	3.00 mm
0.80 mm	28°	3.00 mm	2.50 mm	5.00 mm
1.00 mm	60°	3.00 mm	2.00 mm	5.00 mm
1.20 mm	80°	1.00 mm	0.40 mm	4.00 mm
1.50 mm	80°	3.00 mm	2.00 mm	5.00 mm
1.60 mm	80°	6.00 mm	5.00 mm	8.00 mm
2.00 mm	86°	1.00 mm	0.40 mm	3.20 mm
2.30 mm	88°	1.50 mm	1.00 mm	4.00 mm
2.50 mm	90°	0.40 mm	0.80 mm	6.30 mm
3.00 mm	90°	0.60 mm	0.40 mm	6.30 mm
3.20 mm	90°	0.80 mm	0.40 mm	6.30 mm
4.00 mm	90°	1.20 mm	0.80 mm	6.30 mm
4.75 mm				
5.00 mm				
5.50 mm				
6.00 mm				
6.30 mm				
7.00 mm				
8.00 mm				

**OMS: Standard bottom tools with extra step down relief**

Almost all of our bottom tools with a V-opening from 6 mm up to and including 12 mm are available with customized step down relief of 2 mm at the front and/or back.

**Other specials**

At Wila you are at the right place for “true” special tools. Our Application Engineers are happy to advise you or send your question to [info@wila.nl](mailto:info@wila.nl) or fax it to +31 (0)573 25 75 97.

## BM & OM: Tools with special geometry

The design of these tools depends, among other factors, on the shape of the product, the thickness of the sheet and the required inner radius. The bending method (air bending or bottom bending) is of importance as well. These tools are available in almost any desirable design and with several surface hardenings. The BM (top) and OM (bottom) tools can be delivered with all the New Standard adaptations either top or shoulder load. They are also available in the standard lengths, see also page 20/21.

## OM: Bottom tools with New Standard adaption, NS III and NS IV

The demand for these types of tools is steadily increasing, since both on the upper beam as well as on the lower beam New Standard Clamping is increasingly being utilized.

The advantage of this is that top tools can be placed in the lower clamping and bottom tools in the upper clamping (fig. 3.1).

This is especially beneficial when using a robot for the manipulation of the sheet. This way, there is no need to turn the sheet in case of an opposing bend. In this case, the automatic exchange (ATC) of both bottom as well as top tools is possible. See for additional information page 22/23.

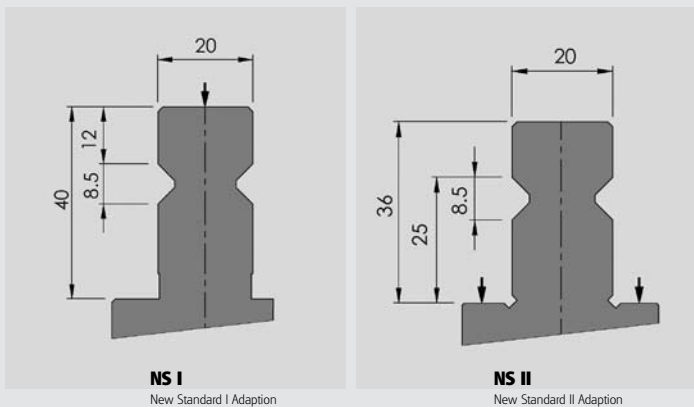

BM Adaption type

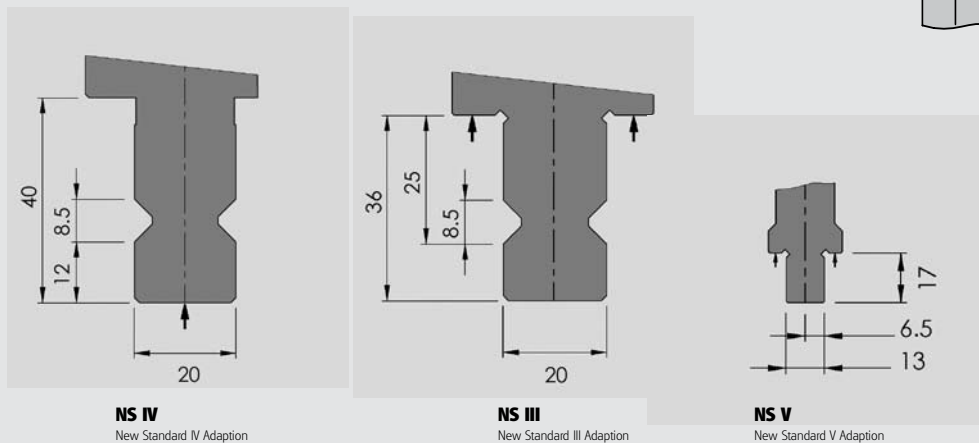

OM Adaption type

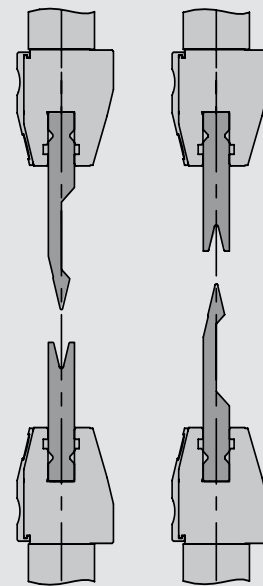
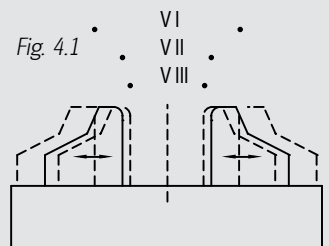

Fig. 3.1

TOOLING

# ADJUSTABLE BOTTOM TOOLS (RS, MULTI-V AND MVM)

Custom Made tools also include bottom tools with an adjustable opening width. The opening width (V-opening) can be adjusted as necessary (Fig. 4.1). The primary advantage offered by these adjustable bottom tools is that the bottom tool need not be changed with the sheet thickness: the opening width can simply be adjusted as necessary. This results in substantial time savings, especially when large dimensions are involved.



The Wila range of products includes three models of adjustable bottom tools:

- customer-specific adjustable bottom tool, type RS;
- standard adjustable bottom tool, type Multi-V;
- programmable bottom tool, type MVM.

**RS**

The adjustable bottom tool type RS (Fig. 4.2) can be produced completely according to the customer's specifications. It consists of a base plate with support blocks, spacers and bending bars. In order to achieve the desired bend opening, the necessary spacers are inserted between the bending bars and the support blocks. The bending bars are CNC-Deepharden<sup>®</sup>, thus minimizing wear.

Fig. 4.2

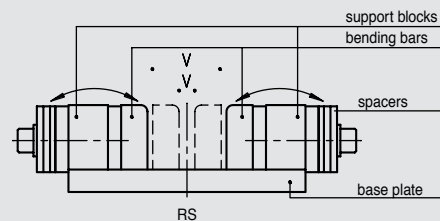

modules. It is possible to choose the desired V-openings by using spacer bars which can be supplied or procured locally. This gives you the possibility to choose the V-opening that best fits the characteristics of the material to be processed. When changing sheet thickness, there is no need to change the bottom tool. The Multi-V is equipped with low friction, hardened roller bars. As a consequence of the low friction of the rolling bars, up to 30% less bending force is required to obtain the same results as with conventional bottom tools.

**Multi-V**

The fully modular adjustable bottom tool type Multi-V (Fig. 4.3) offers a

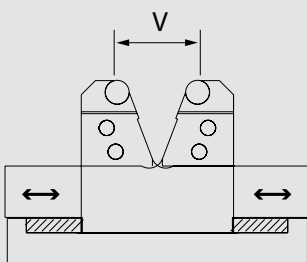

Fig. 4.3 Multi-V

number of advantages. The Multi-V main structure is simple; it consists of multiple elements of the same type which are built together into one tool. In case of damage, it is simple and cost-effective to replace one or more



Multi-V

# CUSTOM STYLE<sup>®</sup> ADJUSTABLE BOTTOM TOOLS

The Multi-V is designed to bend plate material and is available in 4 different models: Model B with V-opening adjustable from 24-124 mm, model D adjustable from 65-180 mm, model E adjustable from 120-300 mm, and model F adjustable from 150- 400mm.

## MVM Type I-1

The programmable bottom tool MVM Type I.1 offers a number of specific advantages. Thanks to the interval-free adjustment possibilities, the optimum V-opening can always be selected. Because the bottom tools (as with standard type OZU) or spacers (as with the adjustable type RS) need not be changed, changeover times are ultra-short. Thanks to the compact construction, the user has optimum bending freedom. Moreover, the construction is extremely stable because it was designed based on the vise principle. It is even possible to combine the system with a hemming tool (e.g. type BIU-051) to pre-bend and to flatten. At the same time, the MVM can be used as a tool holder for other bottom tools with a 13 mm adaption, for example OZU bottom tools from the New Standard or American programs.



MVM Type I-1



Pre-bend and flattening in the same tool.



Acts as a tool holder for OZU bottom tools.

## MVM I.1 CENTRALLY ADJUSTABLE BOTTOM TOOL

V-opening continuously adjustable from 6- 51mm.

DELIVERY	STANDARD	OPTIONAL
CNC drive unit	●	
Manual adjustment with digital read-out.		●
No tool changes required.	●	
Always the ideal V-opening	●	
Bending radii are CNC-Deephardened	●	
Pre-bend and flattening in the same tool	●	
Will act as tool holder for OZU-tooling	●	
Practically Unlimited bend angles (e.g. 30 ° at S=6 mm)	●	

LENGTH	WEIGHT KG	MAX LOAD	PRICE
1190 mm	119		
1530 mm	153		
1785 mm	179		
2040 mm	204		
2380 mm	238	100 T/meter	
2550 mm	255	$\alpha=90^\circ$	
3060 mm	306		
3655 mm	366		
4080 mm	408		
4250 mm	425		

Note: Other lengths available on request

TOOLING

# FLATTENING TOOLS (DD)

Flattening tools (often called Hemming or Dutch bending tools) are used to pre-bend the sheet and then press it closed (fig. 4.4). This technique is used, for example, to finish the sharp edges of the ends of a sheet or to reinforce the sheet and thus strengthen the bent product.

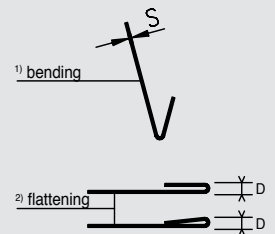

Fig. 4.4

Depending on the available tonnage and the sheet to be bent (material type and thickness), the sheet can be pressed closed to a greater or lesser extent. The force table on page 81 lists the tonnages required for closing the sheet for mild steel 42kN/cm<sup>2</sup> and for stainless steel 70 kN/cm<sup>2</sup>. The values as indicated may deviate slightly in actual practice.

The spring-action flattening tool, consisting of a holder with a spring-action flattening part, is another option (Fig. 4.6). When combined with a 30° top tool, the sheet can be pre-bent and then hemmed. Because the V opening can be adjusted to suit the sheet thickness, short flange lengths can be bent. This combination however cannot be used for universal bending. The range of products includes a number of standard designs, type DDU (page 73).

A variety of tools in the Wila program can be used to perform this bending operation. Using the New Standard top tool type BIU 051, for example, combined with bottom tool type OZU 083, a flattening combination can be created that can be used for both pre-bending and flattening (Fig. 4.5). An advantage is the fact that this tool can also be used for universal bending. Because the design of the configuration is centric, no sliding mechanism is required. We advise a maximum sheet thickness of 2 mm.

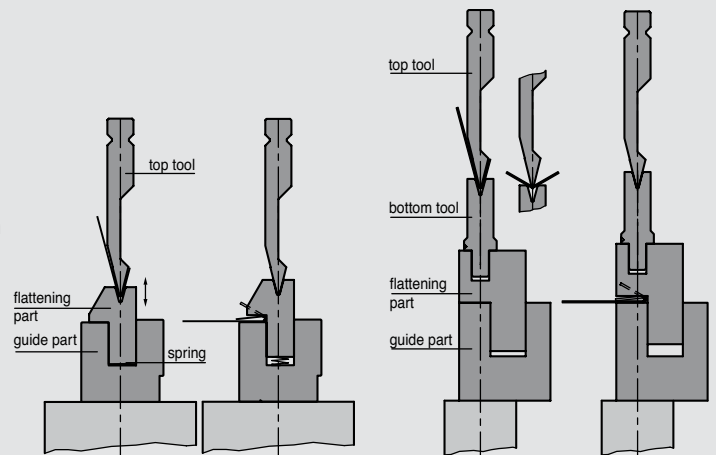

Fig. 4.6

Fig. 4.7

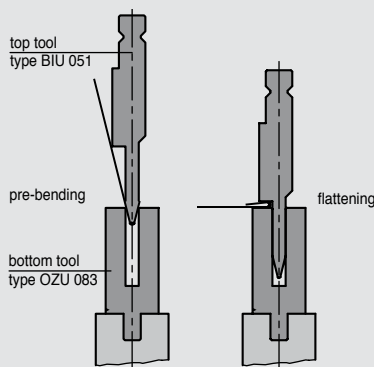

Fig. 4.5

As a modern version of the spring-action Dutch bending tool, Wila offers the hydraulic Dutch bending tool (Fig. 4.7). The pressing part is powered by hydraulic cylinders incorporated in the tool. The inactive tool is therefore in a closed position, and simultaneously serves as a tool holder. Interchangeable tools can be placed in the flattening part, making it possible to adjust the size of the V opening as desired. Wila offers a modified Hydraulic Power Pack for this purpose. Information available on request.



# CUSTOM STYLE<sup>®</sup> FLATTENING TOOLS

The spring-action and hydraulic flattening tools can be mounted on the machine in a number of ways:

- separately on the press brake's table.
- in the clamping slot in the table or lower beam using a clamp holder (Fig. 4.8).
- directly on the lower beam (Fig. 4.9).

The hole pattern is available upon request. Here too, the hole pattern can be modified to suit the customer's needs. Both models can be standardly equipped with additional M16 holes 200 mm center to center, so that support arms and such can be attached.

The bottom tools used with the hydraulic flattening tool can be clamped in the tool in one of two ways:

- mechanically, using standard clamping bolts. These bolts are located in the middle over a length of 1000 mm at 25 mm intervals, in the remaining length the intervals are 100 mm.
- hydraulically, using built in clamping pins.

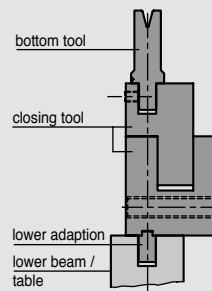

Fig. 4.8

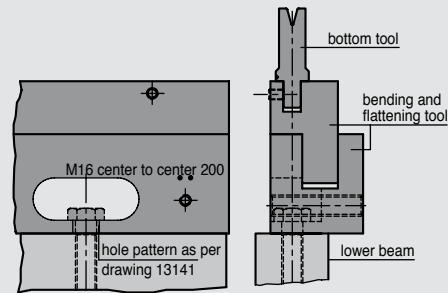
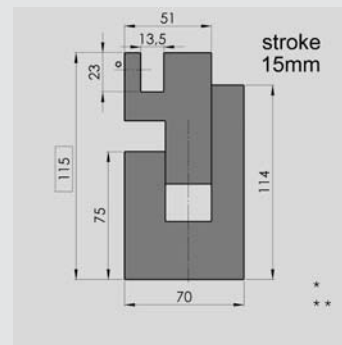

Fig. 4.9

## Example executions of hydraulic flattening tools

### DD-005 BENDING AND FLATTENING TOOL WITH HYDRAULIC LIFTING AND MANUAL CLAMPING

DELIVERY	STANDARD	OPTIONAL
Hydraulic Power Pack		•
Lower adaption		•
Mounting directly to the lower beam		•
Hydraulic tool clamping		•
<i>Usable for:</i>		
New Standard bottom tools	•	
American style bottom tools	•	
Mild steel 0.5-2.0 mm	•	
Aluminum 0.5-2.5 mm	•	



### DD-009HI BENDING AND FLATTENING TOOL WITH HYDRAULIC LIFTING AND HYDRAULIC CLAMPING

DELIVERY	STANDARD	OPTIONAL
Hydraulic Power Pack		•
Lower adaption		•
Mounting directly to the lower beam		•
Manual tool clamping		•
Hardened Flattening Insert	•	
<i>Usable for:</i>		
New Standard bottom tools	•	
American style bottom tools	•	
Mild steel 0.5-3.0 mm	•	
Aluminum 0.5-3.0 mm	•	
Stainless St. 0.5-2.0 mm	•	

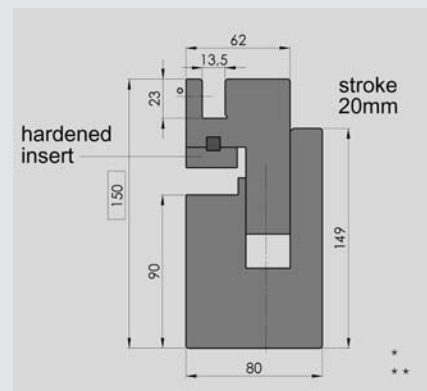

Max. load 100 T/meter.

Note: Other executions available on request.

# CROWNING

With press brakes, the machine frames tend to deflect during the bending process. Without correction, the top tool does not penetrate the bottom die as deeply across the machine length, especially towards the center of the press brake. As a result, the bending angle is not constant over the entire length. Wila has developed a very advanced solution to this common problem.

Wila Crowning systems are characterized by their extremely compact design without any externally moving parts. Control often takes place automatically via a CNC drive motor integrated to the machine controller, eliminating the need for the press brake operator to make adjustments for machine deflection.

The basis of Wila Crowning is the patented 'Wila Wave' opposing wave technology, by which the bottom tools are supported along the entire length. The opposing waves are provided with different slope angles, higher towards the center and shallower towards each end. By shifting the bottom wave in the longitudinal direction with a CNC-operated motor (standard 400V-3PH-50HZ) or with manual adjustment, a curve is created. In this way, the deflection of the entire press brake is automatically compensated proportionately the entire machine length. (Fig. 5.1). The crowning system is also equipped with localized adjustments by which the crowning can be aligned over both the X axis ( $T_x$ , to correct alignment) and Y axis ( $T_y$ , to compensate for unavoidable machining tolerances). The New Standard and American Style crowning systems come standard equipped with an aluminum Cover Strip including an integrated ruler.

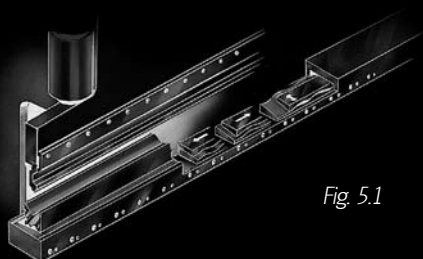

Fig. 5.1



CNC-operated "CNC"



Manually operated with "H" hand crank assembly

All New Standard Premium Crowning systems are outfitted with Guards as standard; with New Standard Pro and American Style crowning systems Guards are optional. All Wila crowning systems have been designed according to the same basic concept and are available in the categories described below.

### New Standard Premium

Crowning with a completely integrated manually or hydraulically operated clamping system. The ultimate in precision, ease of operation, adjustability, durability and clamping and crowning performance. All pressure and reference surfaces are CNC-Dee-phardened® (approx. 56 HRC). Wear is negligible and high performance levels are guaranteed for the long term.

For Premium Crowning models with hydraulic clamping, clamping is achieved by means of a flexible hose which is integrated in the clamping system over the entire length, whereby hydraulic oil pressure (max 50 Bar) is transferred to the tools via hardened clamping pins. Just like with the New Standard Premium Clamping, tool segments as small as 10 mm in length can be clamped individually. The hydraulic connection can be installed on either side of the crowning system. If bottom tool changeovers are not needed often, Premium crowning models with manual clamping are available as well. Manual clamping is achieved via clamping bolts at a distance of every 25 mm across the full length, allowing the clamping of tool segments as small as 15 mm in length at any position.

### New Standard Pro

New Standard Pro Crowning systems are a high-quality alternative for the New Standard Premium Crowning systems. The main difference between the two lines are that the New Standard Pro Crowning systems are not equipped with CNC-Dee-phardened work surfaces. The New Standard Pro Crowning systems are also provided with the patented “Wila Wave” technology as well as Tx and Ty-adjustment. Depending on your requirements, the tools can be clamped either hydraulically or manually. The hydraulic clamping is similar in function to New Standard Premium clamping; with Pro crowning models tool segments as small as 15 mm in length can be clamped anywhere.

Wila delivers the New Standard Pro Crowning in a number of versions, including retrofit models. The retrofit crowning systems can be placed on press brakes with practically any type of bed configuration. Each retrofit model has all the functional characteristics of crowning and clamping as described above, with the exception of the alignment provision in the X-axis. Retrofit crowning models can be supplied with:

- Adaption (B2) for mounting to the slot in the lower beam. (Fig. 5.2).
- Mounting plate B3 for bolting to the lower beam according to the existing hole pattern. (Fig. 5.3).

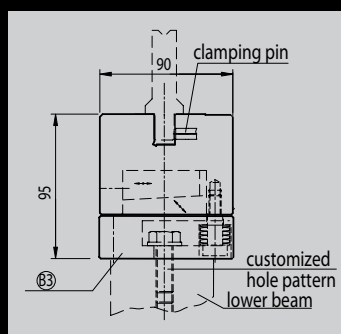

Fig. 5.2

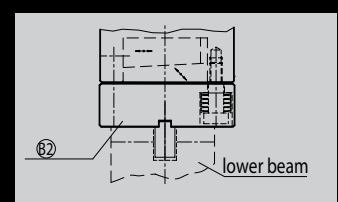

Fig. 5.3



Ty-adjustment



Hydraulic clamping



Manual adjustment in front of the crowning

### American Style

Wila has developed a number of crowning systems specifically for the American market that can be used in combination with Wila American Style or even American planer made bottom tools. They meet the same high requirements and provide the same options as the crowning systems from the New Standard Pro program. American Style Crowning systems are available for press brakes that have been built according to the Universal Press Brake Concept as well as retrofit versions with adaptation or bolt-down mounting.

As indicated, the “Wila Waves” can be adjusted via CNC motor or via manual adjustment. On the New Standard Pro and American Style manual retrofit versions, these can have the operating mechanism for centralized crowning adjustment on the front right of the crowning unit. The advantage of this is that bottom tools can be slid into the tool adaptation from both sides and there is no interference for bending parts off the ends of the crowning systems.

All available adjustment options (right hand side):

- “CNC” means motorized at the end
- “H” means manual at the end
- “Hf” means manual in the front
- “Hy” means hydraulic at the end (used with large units only)

### Custom Style

Besides the standard models mentioned above, Wila also offers customized crowning systems. These, often extremely large, crowning systems can be manufactured to specific requirements of the press brake or the tooling size and type to be used on top of the crowning system. Examples are given on pages 60/61; other versions are available against request.

**NSCR-II-HC-CNC/UPB**

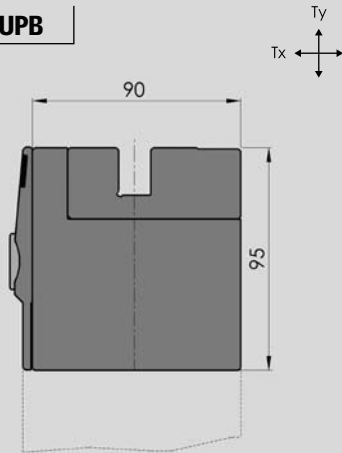

**NSCR-II-HC-CNC/UPB CROWNING WITH HYDRAULIC CLAMPING**

Centrally adjustable crowning for the universal lower beam adaptation with X (Tx) and Y (Ty) alignment. Length built up from modules.

DELIVERY	STANDARD	OPTIONAL
Adaptation CNC-Deepearthened	●	
Coverstrip with scale	●	
Guards	●	
CNC drive unit	●	
Ty in front of Coverstrip	●	
Ty behind Coverstrip		●
Hydraulic Power Pack*		●

LENGTH	WEIGHT KG	MAX LOAD	PRICE
1190 mm	76		
1530 mm	98		
1785 mm	114		
2040 mm	131		
2380 mm	152	Shoulder load 300 T/meter	
2550 mm	163		
3060 mm	196		
3655 mm	234		
4080 mm	261		
4250 mm	272		

**NSCR-II-MC-CNC/UPB**

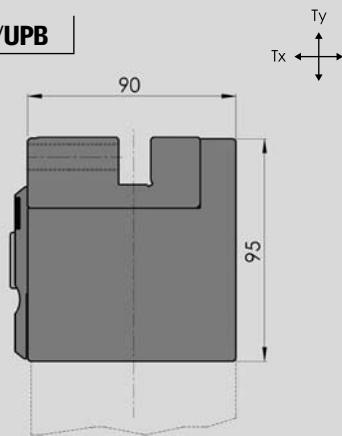

**NSCR-II-MC-CNC/UPB CROWNING WITH MANUAL CLAMPING**

Centrally adjustable crowning for the universal lower beam adaptation with X (Tx) and Y (Ty) alignment. Length built up from modules.

DELIVERY	STANDARD	OPTIONAL
Adaptation CNC-Deepearthened	●	
Coverstrip with scale	●	
Guards	●	
CNC drive unit	●	
Ty in front of Coverstrip	●	
Ty behind Coverstrip		●

LENGTH	WEIGHT KG	MAX LOAD	PRICE
1190 mm	76		
1530 mm	97		
1785 mm	113		
2040 mm	130		
2380 mm	151	Shoulder load 300 T/meter	
2550 mm	162		
3060 mm	194		
3655 mm	232		
4080 mm	259		
4250 mm	270		

Note: For information about the standard equipment and options see page 51 to 52.

\* Hydraulic Power Pack see page 19.

Other lengths available on request

**NSCR-I-HC-CNC/UPB**

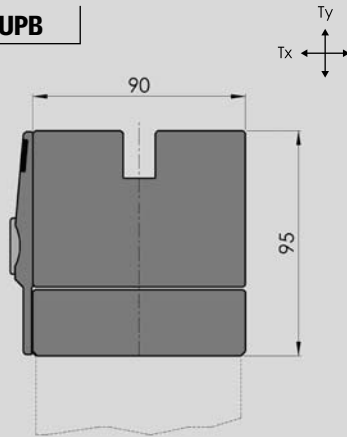

**NSCR-I-HC-CNC/UPB CROWNING WITH HYDRAULIC CLAMPING**

Centrally adjustable crowning for the universal lower beam adaptation with X (Tx) and Y (Ty) alignment.

DELIVERY	STANDARD	OPTIONAL
Coverstrip with scale	●	
Guards		●
CNC drive unit	●	
Manual adjustment		●
Ty in front of Coverstrip		●
Ty behind Coverstrip	●	
Hydraulic Power Pack*		●



LENGTH	WEIGHT KG	MAX LOAD	PRICE
1190 mm	78	Shoulder load 200 T/meter	
1530 mm	100		
1785 mm	117		
2040 mm	133		
2380 mm	155		
2550 mm	167		
3060 mm	200		
3655 mm	239		
4080 mm	266		
4250 mm	278		

**NSCR-I-MC-CNC/UPB**

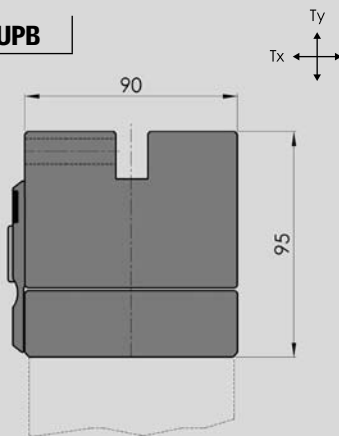

**NSCR-I-MC-CNC/UPB CROWNING WITH MANUAL CLAMPING**

Centrally adjustable crowning for the universal lower beam adaptation with X (Tx) and Y (Ty) alignment.

DELIVERY	STANDARD	OPTIONAL
Coverstrip with scale	●	
Guards		●
CNC drive unit	●	
Manual adjustment		●
Ty in front of Coverstrip		●
Ty behind Coverstrip	●	



LENGTH	WEIGHT KG	MAX LOAD	PRICE
1190 mm	77	Shoulder load 200 T/meter	
1530 mm	99		
1785 mm	116		
2040 mm	132		
2380 mm	154		
2550 mm	165		
3060 mm	198		
3655 mm	237		
4080 mm	264		
4250 mm	275		

Note: For information about the standard equipment and options see page 50 to 52.  
\* Hydraulic Power Pack see page 19.

Other lengths available on request.

**NSCR-I-HC-CNC/B2**

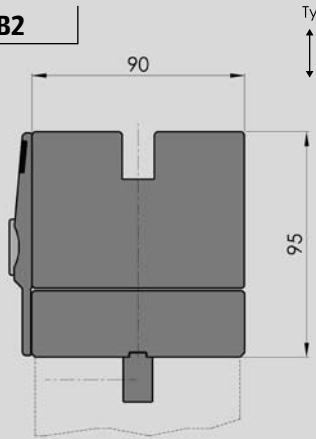

**NSCR-I-HC-CNC/B2 CROWNING WITH HYDRAULIC CLAMPING**

Centrally adjustable crowning with B2 adaption for mounting to the slot in the lower beam, and with Y (Ty) alignment.

DELIVERY	STANDARD	OPTIONAL
Coverstrip with scale	•	
Guards		•
CNC drive unit	•	
Manual adjustment		•
Ty in front of Coverstrip		•
Ty behind Coverstrip	•	
Hydraulic Power Pack*		•

LENGTH	WEIGHT	MAX LOAD	PRICE
	<b>KG</b>		
1190 mm	79		
1530 mm	102		
1785 mm	119		
2040 mm	135		
2380 mm	158	Shoulder load 200 T/meter	
2550 mm	169		
3060 mm	203		
3655 mm	243		
4080 mm	271		
4250 mm	282		

**NSCR-I-MC-CNC/B2**

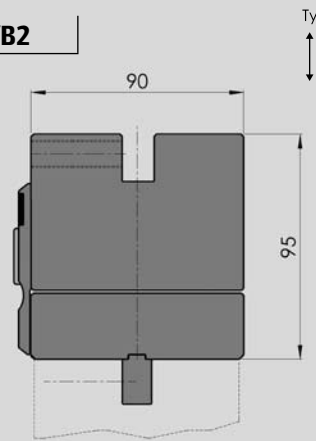

**NSCR-I-MC-CNC/B2 CROWNING WITH MANUAL CLAMPING**

Centrally adjustable crowning with B2 adaption for mounting to the slot in the lower beam, and with Y (Ty) alignment.

DELIVERY	STANDARD	OPTIONAL
Coverstrip with scale	•	
Guards		•
CNC drive unit	•	
Manual adjustment		•
Ty in front of Coverstrip		•
Ty behind Coverstrip	•	

LENGTH	WEIGHT	MAX LOAD	PRICE
	<b>KG</b>		
1190 mm	78		
1530 mm	101		
1785 mm	118		
2040 mm	134		
2380 mm	157	Shoulder load 200 T/meter	
2550 mm	168		
3060 mm	202		
3655 mm	241		
4080 mm	269		
4250 mm	280		

Note: For information about the standard equipment and options see page 50 to 52.

\* Hydraulic Power Pack see page 19.

Other lengths available on request.

**NSCR-I-HC-CNC/B3**

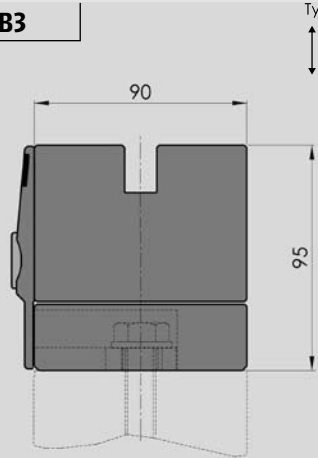

**NSCR-I-HC-CNC/B3 CROWNING WITH HYDRAULIC CLAMPING**

Centrally adjustable crowning for special machined lower beam with B3 bolt-down mounting plate, and Y (Ty) alignment.

DELIVERY	STANDARD	OPTIONAL
Coverstrip with scale	●	
Guards		●
CNC drive unit	●	
Manual adjustment		●
Ty in front of Coverstrip		●
Ty behind Coverstrip	●	
Hydraulic Power Pack*		●

LENGTH	WEIGHT KG	MAX LOAD	PRICE
1190 mm	78	Shoulder load 200 T/meter	
1530 mm	100		
1785 mm	117		
2040 mm	133		
2380 mm	155		
2550 mm	167		
3060 mm	200		
3655 mm	239		
4080 mm	266		
4250 mm	278		

**NSCR-I-MC-CNC/B3**

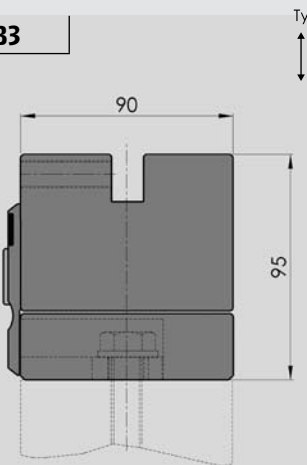

**NSCR-I-MC-CNC/B3 CROWNING WITH MANUAL CLAMPING**

Centrally adjustable crowning for special machined lower beam with B3 bolt-down mounting plate, and Y (Ty) alignment.

DELIVERY	STANDARD	OPTIONAL
Coverstrip with scale	●	
Guards		●
CNC drive unit	●	
Manual adjustment		●
Ty in front of Coverstrip		●
Ty behind Coverstrip	●	

LENGTH	WEIGHT KG	MAX LOAD	PRICE
1190 mm	77	Shoulder load 200 T/meter	
1530 mm	99		
1785 mm	116		
2040 mm	132		
2380 mm	154		
2550 mm	165		
3060 mm	198		
3655 mm	237		
4080 mm	264		
4250 mm	275		

Note: For information about the standard equipment and options see page 50 to 52.

\* Hydraulic Power Pack see page 19.

Other lengths available on request.



## D(1+2)

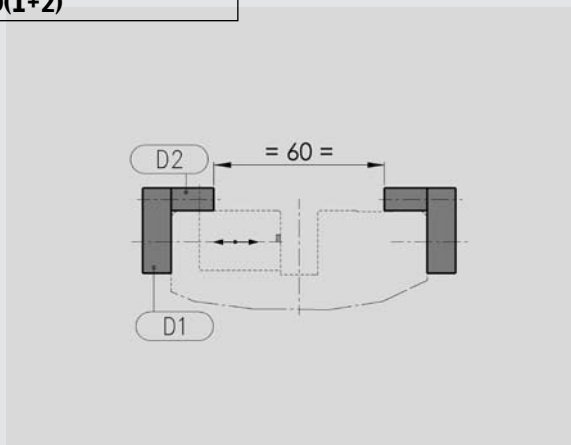

## D(1+2) CLAMP BARS

Makes the crowning suitable for European Style bottom tools with a width of 60 mm.

LENGTH	WEIGHT	PRICE
	KG	
510 mm (D1)	1.2	
510 mm (D2)	0.6	



## 4-WAY DIE CLAMP SET

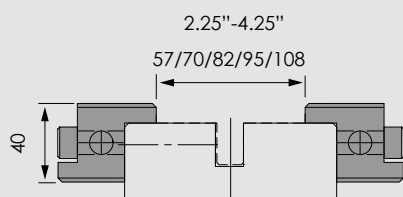

## 4-WAY DIE CLAMP SET

Makes the crowning suitable for 4-ways dies with block size 2 1/4"; 2 3/4"; 3 1/4"; 3 3/4"; 4 1/4". One set includes 8 clamps.

SET	WEIGHT	PRICE
	KG	
4-way die clamp set	1.5	



**ASCR-I-HC-CNC/UPB**

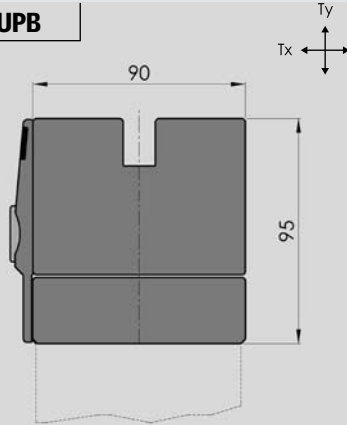

**ASCR-I-HC-CNC/UPB CROWNING WITH HYDRAULIC CLAMPING**

Centrally adjustable crowning for the universal lower beam adaptation with X (Tx) and Y (Ty) alignment.

DELIVERY	STANDARD	OPTIONAL
Coverstrip with scale	●	
Guards		●
CNC drive unit	●	
Manual adjustment		●
Ty in front of cover		●
Ty behind cover	●	
B3 bolt-down		●
Hydraulic Power Pack*		●



LENGTH	WEIGHT KG	MAX LOAD	PRICE
1190 mm	78	Shoulder load 200 T/meter	
1530 mm	100		
1785 mm	117		
2040 mm	133		
2380 mm	155		
2550 mm	167		
3060 mm	200		
3655 mm	239		
4080 mm	266		
4250 mm	278		

**ASCR-I-MC-CNC/UPB**

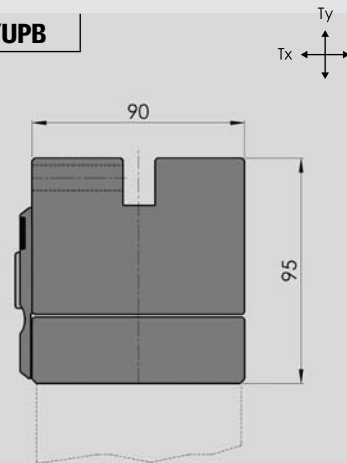

**ASCR-I-MC-CNC/UPB CROWNING WITH MANUAL CLAMPING**

Centrally adjustable crowning for the universal lower beam adaptation with X (Tx) and Y (Ty) alignment.

DELIVERY	STANDARD	OPTIONAL
Coverstrip with scale	●	
Guards		●
CNC drive unit	●	
Manual adjustment		●
Ty in front of cover		●
Ty behind cover	●	
B3 bolt-down		●

LENGTH	WEIGHT KG	MAX LOAD	PRICE
1190 mm	77	Shoulder load 200 T/meter	
1530 mm	99		
1785 mm	116		
2040 mm	132		
2380 mm	154		
2550 mm	165		
3060 mm	198		
3655 mm	237		
4080 mm	264		
4250 mm	275		

Note: For information about the standard equipment and options see page 50 to 52.  
\* Hydraulic Power Pack see page 19.

Other lengths available on request.

## ASCR-I-HC-CNC/B2

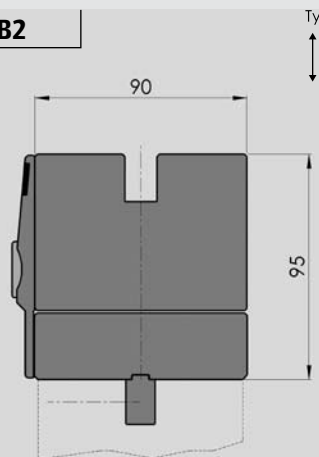

### ASCR-I-HC-CNC/B2 CROWNING WITH HYDRAULIC CLAMPING

Centrally adjustable crowning with B2 adaption for mounting to the slot in the lower beam, and with Y (Ty) alignment.

DELIVERY	STANDARD	OPTIONAL
Coverstrip with scale	●	
Guards		●
CNC drive unit	●	
Manual adjustment		●
Ty in front of cover		●
Ty behind cover	●	
Hydraulic Power Pack*		●

LENGTH	WEIGHT KG	MAX LOAD	PRICE
1190 mm	79		
1530 mm	102		
1785 mm	119		
2040 mm	135		
2380 mm	158	Shoulder load 200T/meter	
2550 mm	169		
3060 mm	203		
3655 mm	243		
4080 mm	271		
4250 mm	282		

## ASCR-I-MC-HF/B2

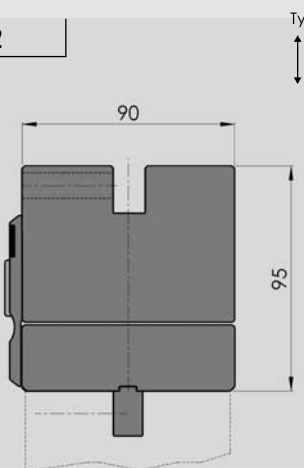

### ASCR-I-MC-HF/B2 CROWNING WITH MANUAL CLAMPING

Centrally adjustable crowning with B2 adaption for mounting to the slot in the lower beam, and Y (Ty) alignment.

DELIVERY	STANDARD	OPTIONAL
Coverstrip with scale	●	
Guards		●
CNC drive unit		●
Manual adjustment in front	●	
Ty in front of cover		●
Ty behind cover	●	



Manual adjustment in front "HF"

LENGTH	WEIGHT KG	MAX LOAD	PRICE
1190 mm	78		
1530 mm	100		
1785 mm	117		
2040 mm	134		
2380 mm	156	Shoulder load 200 T/meter	
2550 mm	167		
3060 mm	201		
3655 mm	240		
4080 mm	268		
4250 mm	279		

Other lengths available on request.

Note: For information about the standard equipment and options see page 50 to 52.

\* Hydraulic Power Pack see page 19.

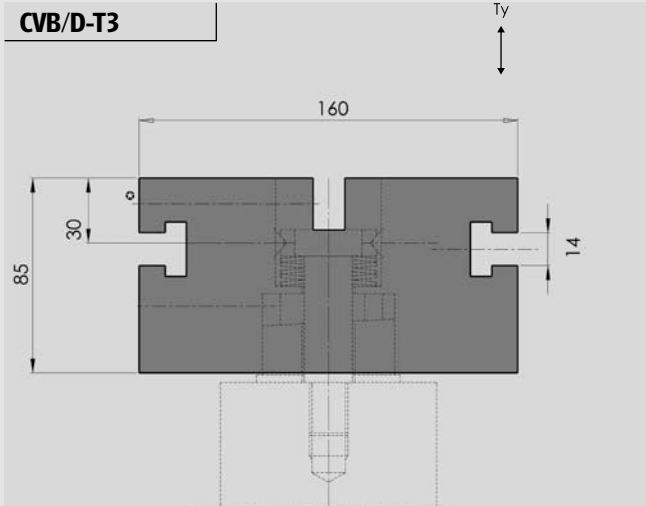

**CVB/D-T3**

Centrally adjustable crowning system, model T3 with flat top. Suitable for holding square bottom tools and single V-tools (New Standard and American Style). Localized Y (Ty) adjustment at every 200 mm, by push and pull screws. Can be supplied with CNC motor or with hand crank assembly.

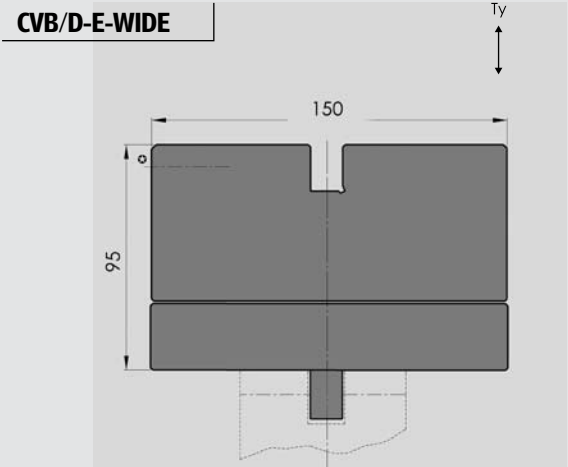

**CVB/D-E-WIDE**

Centrally adjustable crowning system, with mechanical clamping and localized Y (Ty) alignment. Suitable for holding single V-tools (New Standard and American Style). Can be supplied with CNC motor or with hand crank assembly.

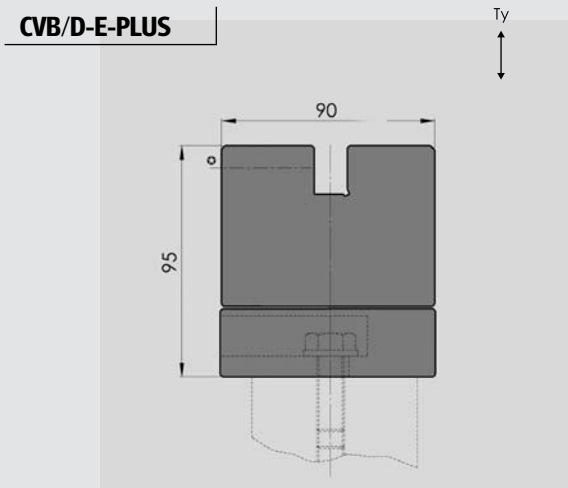

**CVB/D-E-PLUS**

Centrally adjustable crowning system, with mechanical clamping and localized Y (Ty) alignment. Comes with hand crank assembly and mechanical counter. With bolt-down base (optional adaptations available for slot in bed mounting). Can be supplied with CNC motor or with hand crank assembly.

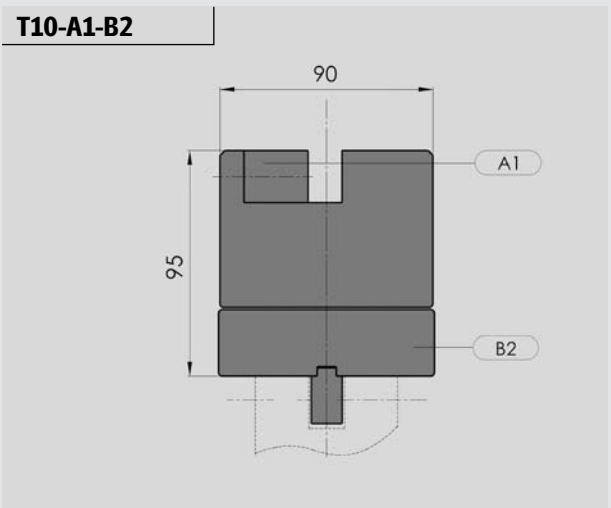

**T10-A1-B2 WITH MANUAL CLAMPING BARS**

Centrally adjustable crowning system with manual clamping bars, and localized adjustments Ty. A1 manual clamping bars, and B2 adaption mounting plate. Can be supplied with CNC motor or with hand crank assembly.

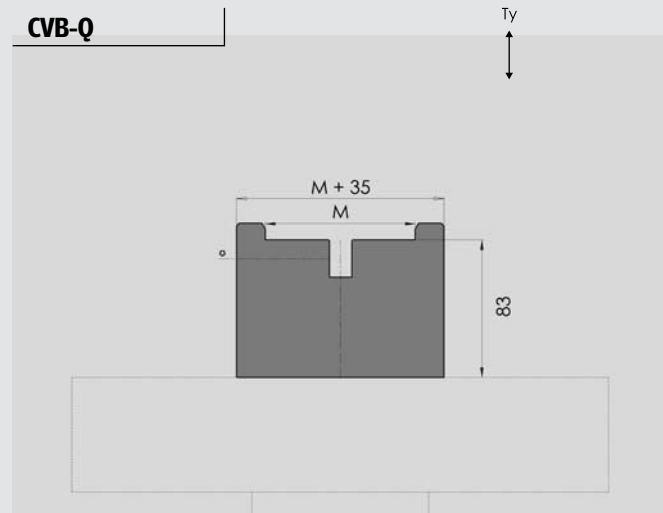
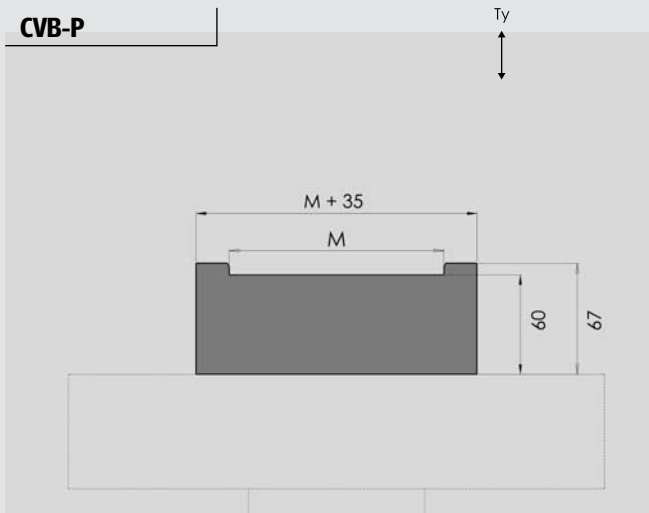

**CVB-P**

Centrally adjustable crowning system, suitable for square bottom tools (M dimensions needed with order). To be placed on top of the table.

**CVB-Q**

Centrally adjustable crowning system, suitable for square bottom tools (M dimensions needed with order). To be placed on top of the table; with B2 adaption mounting optional.

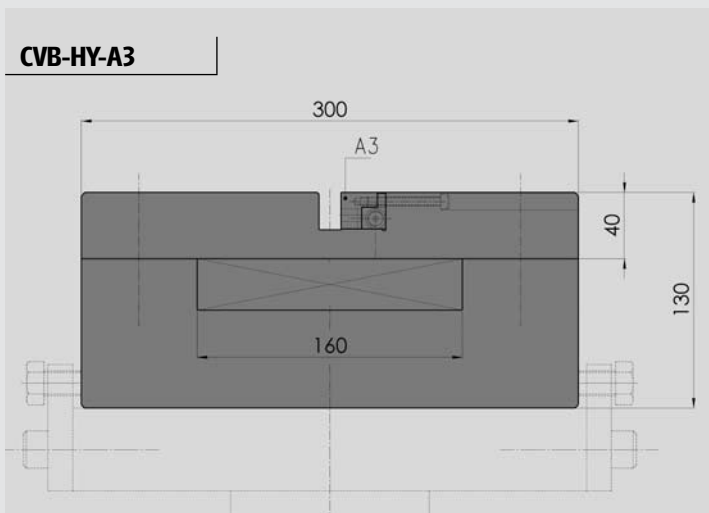

**CVB-HY-A3**

Centrally adjustable crowning system with flat top and A3 hydraulic clamping pins. Suitable for square bottom tools and single V-tools. To be placed on top of the table. Requires Hydraulic Power Pack, see page 19.

# BOTTOM TOOL HOLDERS

Bottom Tool Holders have a variety of functions. They are often used on shorter length press brakes where a crowning system is not required or where there is a crowning system already built into the lower beam of the press brake. Bottom tool holders can be outfitted with hydraulic clamping pins for quick changeover of segmented single V-dies. They can also be used as necessary distance pieces or they can be outfitted with wedges on the bottom to bring the ram and bed parallel to each other. Wila Bottom Tool Holders stand out in their functional design, their completely integrated clamping system for bottom tools and their easy, often automatic, operation. With our extensive range of models available, we are able to provide the right Bottom Tool Holder to meet your particular need.



## **New Standard Premium**

Comes with completely integrated clamping system, either operated hydraulically or manually. The standard for quality and durability. New Standard Premium Bottom Tool Holders are CNC-Deeaphardened® and precision ground for a high-quality finish, highest precision, and an extremely long life span. This allows you to take advantage of superior accuracy as well as excellent clamping performance for the long term.

## **Standard Bottom Tool Holders New Standard Premium**

- Top surface built up from CNC-Deeaphardened® modules with lengths of approx. 500 mm.
- Hydraulic systems offer unsurpassed clamping force via oil pressure up to 50 Bar Hardened clamping pins apply individual pressure on segmented single V-dies as small as 10 mm.

- Both the hydraulic and manual clamping systems are sealed against any dirt or scale contamination.
- Integrated tool holder body is made out of one piece from high tensile CrMo steel alloy (approx. 1100 N/mm<sup>2</sup>) for ultimate rigidity.
- Load-bearing capacity up to 300 ton/meter with a minimum tool width of 40 mm.

## **New Standard Pro**

The New Standard Pro line of Bottom Tool Holders are also available with either hydraulic or manual clamping and offer many of the same features of Premium Bottom Tool Holders except for not having the CNC-Deeaphardened clamping surface. There are a large variety of models and lengths of New Standard Pro Bottom Tool Holders and they are offered at a very appealing price/quality ratio.

**Standard Bottom Tool Holders New Standard Pro**

- Excellent clamping force applied from hydraulic oil pressure of 50 Bar.
- Hardened clamping pins apply individual pressure on segmented single V-dies as small as 10 mm.
- Durable clamping device; not susceptible to contamination; slim construction provides for maximum part clearance.
- Manufactured from high-quality tool steel, load-bearing capacity of up to 200 ton/meter with a minimum tool width of 45 mm.

**American Style**

Any of the New Standard Premium or New Standard Pro Bottom Tool Holders, be they hydraulic or manually operated, can be used with American Style bottom tools.

**Standard Bottom Tool Holders OB**

- Manufactured from high quality tool steel in machine length. Good durability with load capacity of 200 tons per meter with a minimum tool width of 45mm.
- Mechanical tool clamping with clamping bolts every 25mm in the center 1000mm. For perfect clamping of tool segments with a length from 20 mm.
- Suitable for New Standard or American style bottom tools.

**Custom Made Bottom Tool Holders**

Wila can manufacture Custom Made Bottom Tool Holders according to the customer's specifications. There are practically no limitations with regard to sizes, material choice, special provisions for mounting, or any other requirements the customer might have.

**Hydro Power Packs**

Wila also supplies a Hydraulic Power Pack for OB Bottom Tool Holders which have hydraulic clamping capability (see page 19). The Power Packs can be operated via remote control or tied to the press brake control. In cases where the customer changes their bottom tooling infrequently, Wila also offers a manually operated Hydraulic Power Pack at very attractive pricing, which allows you to take advantage of the speed and flexibility of hydraulic clamping at a lower price.

**Ty/Tx**

In a number of cases, a separate crowning system is not required, either because the press brake is very short and has limited deflection or because a crowning provision is already built into the lower beam. However, there are other provisions which are built into Wila Bottom Tool Holders that are necessary in order to produce accurate parts consistently, namely, the ability to perfectly align bottom tools and the ability to eliminate tolerances in the Y-axis (Ty). These local deviations, as well as inaccuracies because of wear, can easily be corrected. Production losses and costs for scrap and re-work are no longer necessary and the life span of the machine is increased as well. Across the entire length of the machine, the Bottom Tool Holder can be aligned with adjustment screws in the X-axis (Tx) in relation to the back gauge. Exceptionally stringent requirements to the straightness of the lower beam are no longer necessary.

**OB-II-HC-TY/ES IV**

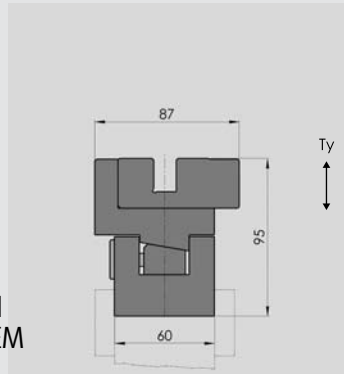

BOTTOM TOOL HOLDER WITH HYDRAULIC CLAMPING SYSTEM

DELIVERY	STANDARD	OPTIONAL
Tooling adaptation CNC-Dee-phardened®	●	
Ty-alignment	●	
B2 adaption, UPB or B3 bolt-down mounting**		●
Hydraulic Power Pack*		●
<b>Usable for:</b>		
New Standard single V-tools	●	
American style single V-tools	●	

LENGTH	WEIGHT	MAX LOAD	PRICE
	KG		
1190 mm	60		
1530 mm	77		
1785 mm	90		
2040 mm	103		
2380 mm	120	Shoulder load	
2550 mm	129	300 T/meter	
3060 mm	155		
3655 mm	185		
4080 mm	206		
4250 mm	215		

**OB-II-MC-TY/ES IV**

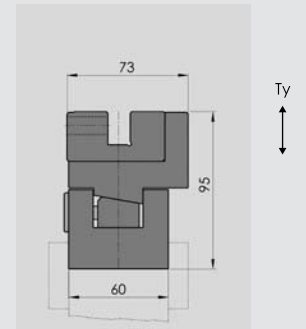

BOTTOM TOOL HOLDER WITH MANUAL CLAMPING SYSTEM

DELIVERY	STANDARD	OPTIONAL
Tooling adaptation CNC-Dee-phardened®	●	
Ty-alignment	●	
B2 adaption, UPB or B3 bolt-down mounting**		●
<b>Usable for:</b>		
New Standard single V-tools	●	
American style single V-tools	●	

LENGTH	WEIGHT	MAX LOAD	PRICE
	KG		
1190 mm	56		
1530 mm	72		
1785 mm	84		
2040 mm	96		
2380 mm	112	Shoulder load	
2550 mm	120	300 T/meter	
3060 mm	144		
3655 mm	173		
4080 mm	193		
4250 mm	201		

**OB-II-HC/ES IV**

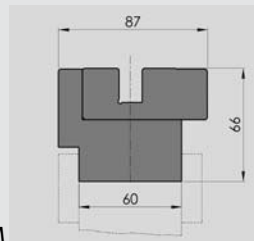

BOTTOM TOOL HOLDER WITH HYDRAULIC CLAMPING SYSTEM

DELIVERY	STANDARD	OPTIONAL
Tooling adaptation CNC-Dee-phardened®	●	
B2 adaption, UPB or B3 bolt-down mounting**		●
Hydraulic Power Pack*		●
<b>Usable for:</b>		
New Standard single V-tools	●	
American style single V-tools	●	

LENGTH	WEIGHT	MAX LOAD	PRICE
	KG		
1190 mm	44		
1530 mm	56		
1785 mm	66		
2040 mm	75		
2380 mm	88	Shoulder load	
2550 mm	94	300 T/meter	
3060 mm	113		
3655 mm	135		
4080 mm	150		
4250 mm	156		

**OB-II-MC/ES IV**

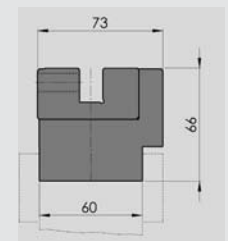

BOTTOM TOOL HOLDER WITH MANUAL CLAMPING SYSTEM

DELIVERY	STANDARD	OPTIONAL
Tooling adaptation CNC-Dee-phardened®	●	
B2 adaption, UPB or B3 bolt-down mounting**		●
<b>Usable for:</b>		
New Standard single V-tools	●	
American style single V-tools	●	

LENGTH	WEIGHT	MAX LOAD	PRICE
	KG		
1190 mm	40		
1530 mm	51		
1785 mm	60		
2040 mm	68		
2380 mm	80	Shoulder load	
2550 mm	85	300 T/meter	
3060 mm	103		
3655 mm	122		
4080 mm	137		
4250 mm	142		

Note: For information about the standard equipment and options see page 62 - 63.  
\* Hydraulic Power Pack see page 19.

Other lengths available on request.  
\*\* Height may increase.



**OB-I-HC-TY/ES IV**

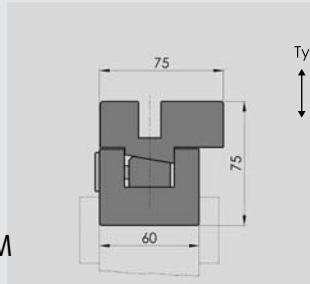

BOTTOM TOOL HOLDER WITH HYDRAULIC CLAMPING SYSTEM

DELIVERY	STANDARD	OPTIONAL
Ty-alignment	●	
B2 adaption, UPB or B3 bolt-down mounting**		●
Hydraulic Power Pack*		●
<b>Usable for:</b>		
New Standard single V-tools	●	
American style single V-tools	●	

LENGTH	WEIGHT	MAX LOAD	PRICE
	KG		
1190 mm	42		
1530 mm	54		
1785 mm	63		
2040 mm	72		
2380 mm	84	Shoulder load	
2550 mm	90	200 T/meter	
3060 mm	108		
3655 mm	129		
4080 mm	144		
4250 mm	150		

**OB-I-MC-TY/ES IV**

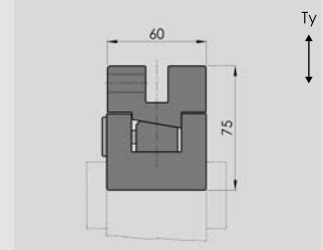

BOTTOM TOOL HOLDER WITH MANUAL CLAMPING SYSTEM

DELIVERY	STANDARD	OPTIONAL
Ty-alignment	●	
B2 adaption, UPB or B3 bolt-down mounting**		●
<b>Usable for:</b>		
New Standard single V-tools	●	
American style single V-tools	●	

LENGTH	WEIGHT	MAX LOAD	PRICE
	KG		
1190 mm	38		
1530 mm	49		
1785 mm	57		
2040 mm	65		
2380 mm	76	Shoulder load	
2550 mm	81	200 T/meter	
3060 mm	97		
3655 mm	116		
4080 mm	130		
4250 mm	135		

**OB-I-HC/ES IV**

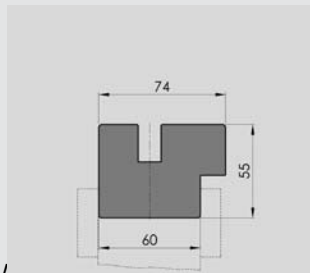

BOTTOM TOOL HOLDER WITH HYDRAULIC CLAMPING SYSTEM

DELIVERY	STANDARD	OPTIONAL
B2 adaption, UPB or B3 bolt-down mounting**		●
Hydraulic Power Pack*		●
<b>Usable for:</b>		
New Standard single V-tools	●	
American style single V-tools	●	

LENGTH	WEIGHT	MAX LOAD	PRICE
	KG		
1190 mm	32		
1530 mm	41		
1785 mm	48		
2040 mm	54		
2380 mm	64	Shoulder load	
2550 mm	68	200 T/meter	
3060 mm	82		
3655 mm	98		
4080 mm	109		
4250 mm	113		

**OB-I-MC/ES IV**

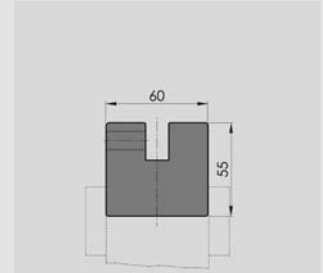

BOTTOM TOOL HOLDER WITH MANUAL CLAMPING SYSTEM

DELIVERY	STANDARD	OPTIONAL
B2 adaption, UPB or B3 bolt-down mounting**		●
<b>Usable for:</b>		
New Standard single V-tools	●	
American style single V-tools	●	

LENGTH	WEIGHT	MAX LOAD	PRICE
	KG		
1190 mm	28		
1530 mm	36		
1785 mm	42		
2040 mm	48		
2380 mm	55	Shoulder load	
2550 mm	59	200 T/meter	
3060 mm	71		
3655 mm	85		
4080 mm	95		
4250 mm	99		

Note: For information about the standard equipment and options see page 62 - 63.

\* Hydraulic Power Pack see page 19.

Other lengths available on request.

\*\* Height may increase.

**OB-958**

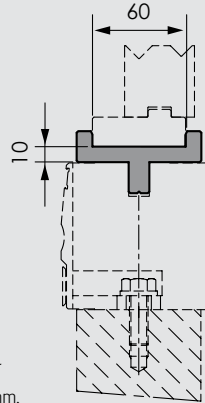

**EUROPEAN INSERT**

Makes the crowning with a Cover strip suitable for European Style bottom tools with a width of 60 mm.

LENGTH	WEIGHT	MAX LOAD	PRICE
	KG		
1190 mm	12		
1530 mm	15		
1785 mm	17		
2040 mm	20		
2380 mm	23	Shoulder load	
2550 mm	25	200 T/meter	
3060 mm	30		
3655 mm	35		
4080 mm	40		
4250 mm	41		

**OB-811**

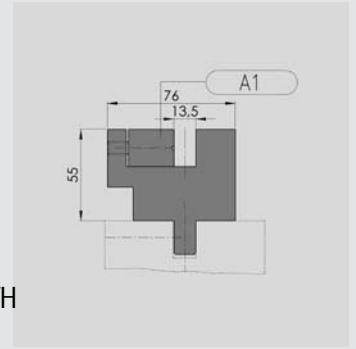

**BOTTOM TOOL HOLDER WITH MANUAL CLAMPING BARS**

DELIVERY	STANDARD	OPTIONAL
A1 clamping bar	•	
Flat Bottom Mounting		•
<b>Usable for:</b>		
New Standard single V-tools.	•	
American style single V-tools.	•	

LENGTH	WEIGHT	MAX LOAD	PRICE
	KG		
1190 mm	38		
1530 mm	49		
1785 mm	57		
2040 mm	65		
2380 mm	76	Shoulder load	
2550 mm	81	200 T/meter	
3060 mm	97		
3655 mm	116		
4080 mm	130		
4250 mm	135		

**OB-953**

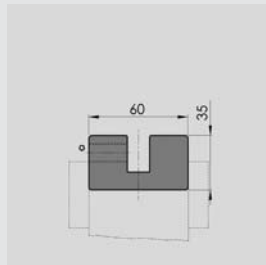

**BOTTOM TOOL HOLDER WITH MANUAL CLAMPING**

DELIVERY	STANDARD	OPTIONAL
B2 adaption, UPB or B3 bolt-down*		•
<b>Usable for:</b>		
New Standard single V-tools.	•	
American style single V-tools.	•	

LENGTH	WEIGHT	MAX LOAD	PRICE
	KG		
515 mm	8		
1190 mm	17		
1530 mm	22		
1785 mm	26		
2040 mm	30		
2380 mm	35	Shoulder load	
2550 mm	37	200 T/meter	
3060 mm	45		
3655 mm	53		
4080 mm	60		
4250 mm	62		

**OB-EUR-1/UPB**

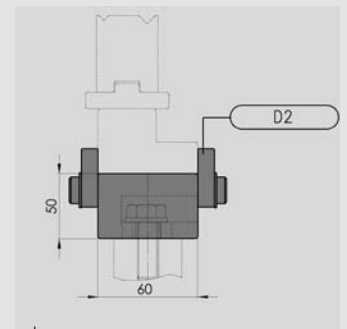

**BOTTOM TOOL HOLDER WITH MANUAL CLAMPING**

Bottom tool holder for mounting directly to the lower beam.

DELIVERY	STANDARD	OPTIONAL
Ty-alignment	•	
D1 clamping bars		•
<b>Usable for:</b>		
New Standard single V-tools.	•	
American style single V-tools.	•	

LENGTH	WEIGHT	MAX LOAD	PRICE
	KG		
1190 mm	34		
1530 mm	44		
1785 mm	51		
2040 mm	59		
2380 mm	69	Shoulder load	
2550 mm	73	200 T/meter	
3060 mm	88		
3655 mm	105		
4080 mm	118		
4250 mm	122		

Note: For information about the standard equipment and options see page 62 - 63.

Other lengths available on request.

\* Height may increase.

# ACCESSORIES

To complement its Clamping, Crowning, and Tooling lines, Wila offers an extensive Accessories program to provide additional versatility to the sheet metal fabricator. Be it radius tooling, offset tooling, adjustable die systems, part marking prevention materials, or tooling storage systems (see also page 76), Wila has the solution for you.

## The range

The Accessories program consists of many value-added accessories for the New Standard Premium, New Standard Pro and American Style lines, including:

- Holders (HU) and Inserts for offset bends (INZU-001, and -002) or for flattening (INZU-003 and -004).
- INZU synthetic inserts for avoiding marking of cosmetic sheet materials (INZU-005 to INZU-007).  
A special Adiprene insert is also available for this type of application (K-001).
- Protective foils in several thicknesses (K-002 to K-005) to avoid part marking.
- Radius Holders (HU) and Inserts (RU) for a large range of common radii from 7mm to 50mm in both CNC-Deephardened® and non-hardened versions.
- Special Roller Tables to assist in flattening hems from thicker sheet materials.
- Adapters to be able to go between different tooling styles: New Standard, American, European (TSU).
- Extenders to use with top tools for deep box bending.
- Bottom Risers to assist in bending long down flanges or to close tool heights
- Flattening Tools for hemming (DDU).



*Radius Holder (HU) with Inserts (RU)*

**TSU-020**

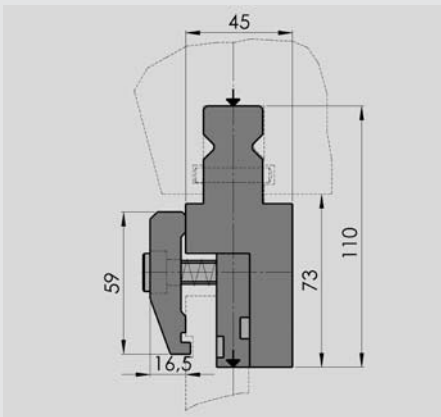

**TSU-021**

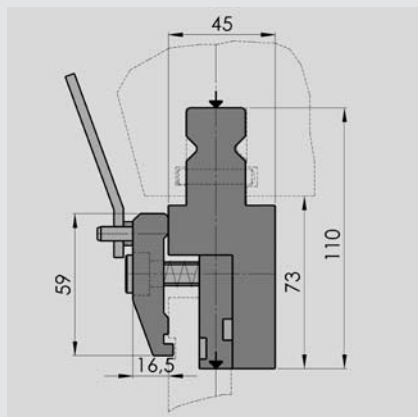

**TSU-022**

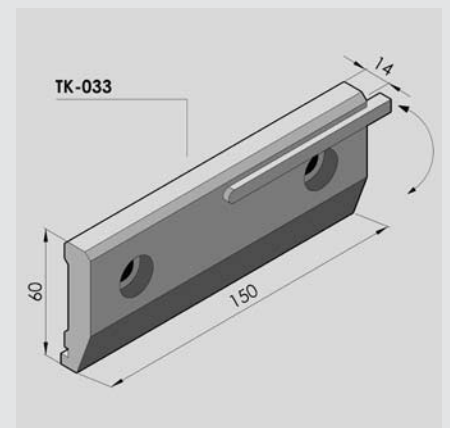
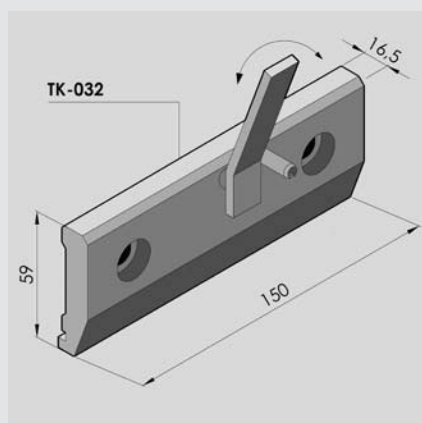
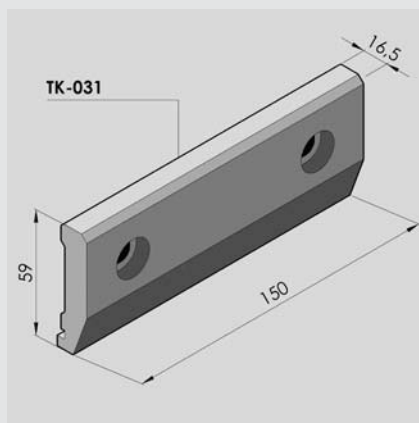
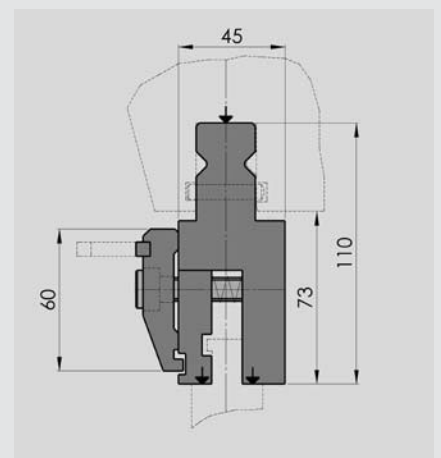
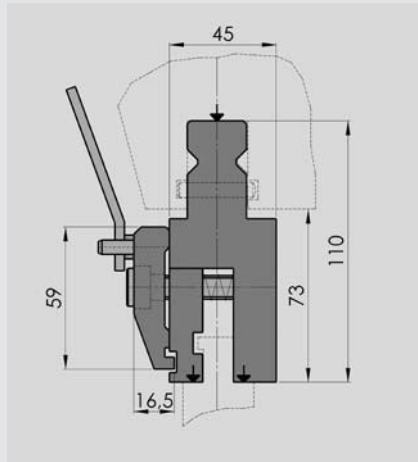
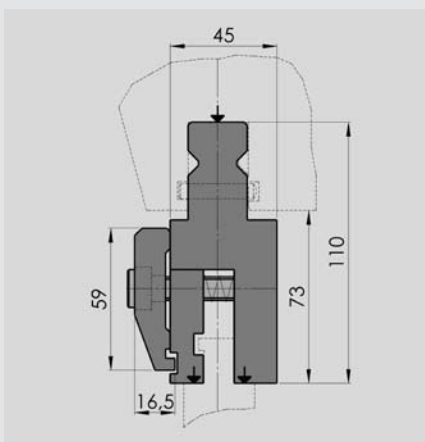
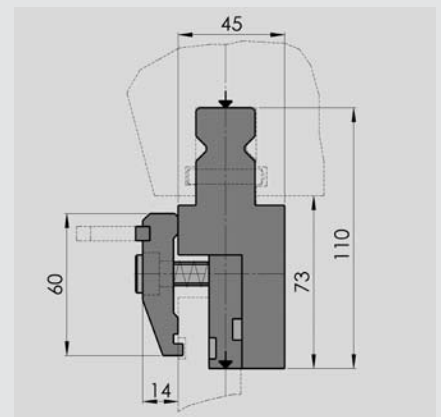

TYPE	LENGTH	WEIGHT	MAX LOAD	PRICE	REMARKS
		KG			
TSU-020/1	515 mm	16.2	100 T/Mtr.	.....	Adapter, New Standard to European or American. Top provided with New Standard adaption and safety pins. Bottom side interchangeable between European Style I and American Style adaptation and with clamping plate type TK-031.
TSU-020/4	150 mm	4.8			
TSU-021/1	515 mm	16.2	100 T/Mtr.	.....	Adapter, New Standard to European or American. Top provided with New Standard adaption and safety pins. Bottom side interchangeable between European Style I and American Style adaptation and with clamping plate type TK-032.
TSU-021/4	150 mm	4.8			
TSU-022/1	515 mm	16.2	100 T/Mtr.	.....	Adapter, New Standard to European or American. Top provided with New Standard adaption and safety pins. Bottom side interchangeable between European Style I and American Style adaptation and with clamping plate type TK-033.
TSU-022/4	150 mm	4.8			

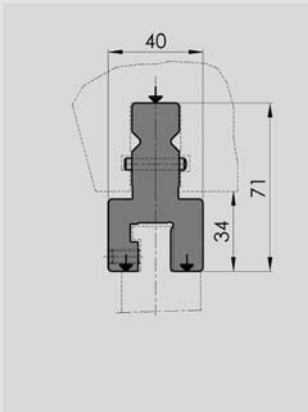
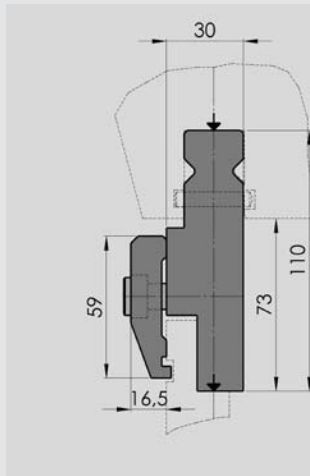
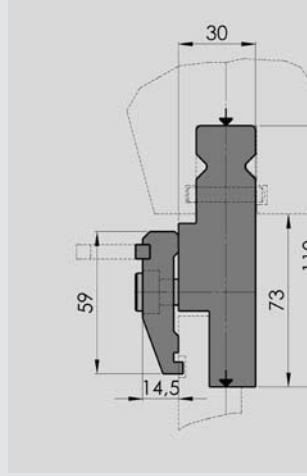
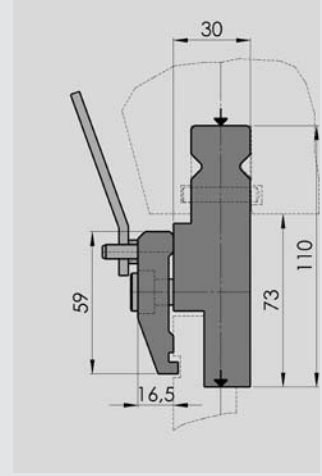
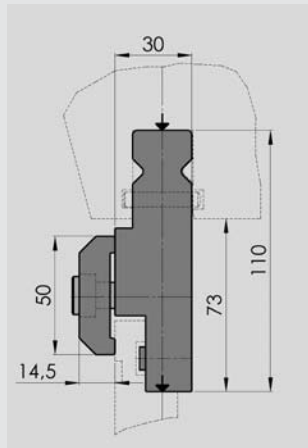
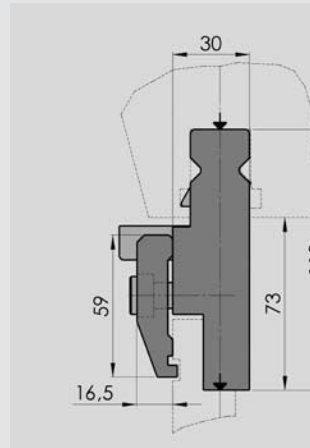
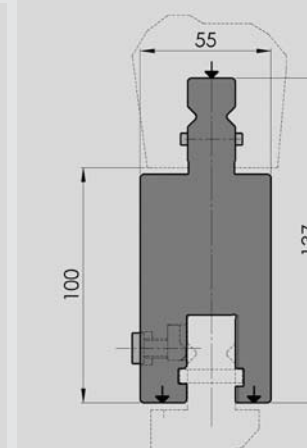
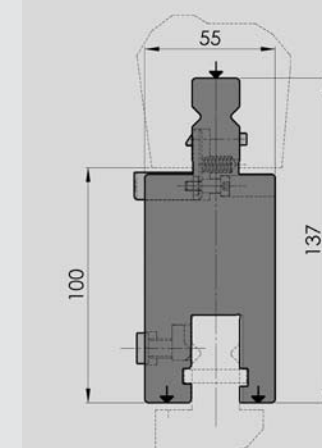
**TSU-023**

**TSU-024**

**TSU-025**

**TSU-026**

**TSU-027**

**TSU-028**

**TSU-029**

**TSU-030**

TYPE	LENGTH	WEIGHT	MAX LOAD	PRICE	REMARKS
		KG			
TSU-023/1	515 mm	71			
TSU-023/4	150 mm	2.7	100 T/Mtr.		Adapter, New Standard to American Style. Top provided with New Standard adaption and safety pins. Bottom provided with American Style I adaptation and 1 clamping screw every 100 mm.
TSU-024/1	515 mm	12.9			
TSU-024/4	150 mm	3.9	100 T/Mtr.		Adapter, New Standard to European Style. Top provided with New Standard adaption and safety pins. Bottom provided with European Style I adaptation and with clamping plate type TK-031 (see TSU-020).
TSU-025/1	515 mm	12.9			
TSU-025/4	150 mm	3.9	100 T/Mtr.		Adapter, New Standard to European Style. Top provided with New Standard adaption and safety pins. Bottom provided with European Style I adaptation and with clamping plate type TK-033 (see TSU-022).
TSU-026/1	515mm	12.9			
TSU-026/4	150mm	3.9	100 T/Mtr.		Adapter, New Standard to European Style. Top provided with New Standard adaption and safety pins. Bottom provided with European Style I adaptation and with clamping plate type TK-032 (see TSU-021).
TSU-027/1	515 mm	12.6			
TSU-027/4	150 mm	4.8	100 T/Mtr.		Adapter, top provided with New Standard adaption and safety pins. Bottom provided with European Style I adaptation with extra safety-slot, and with clamping plate type TK-034.
TSU-028/4	150 mm	4.9	100 T/Mtr.		Adapter, New Standard to European Style with Safety-Clicks. Top provided with New Standard adaption and Safety-Clicks. Bottom European Style I adaptation and provided with clamping plate type TK-035 (see TS-024, however provided with extra opening for Safety-Clicks).
TSU-029/1	515 mm	22.2			
TSU-029/4	150 mm	8.6	100 T/Mtr.		Extender, top and bottom provided with New Standard adaption and adaptation. Top side, adaption provided with safety pins/keys. Bottom side with clamping bar.
TSU-030/4	150 mm	8.6	100 T/Mtr.		Extender, top and bottom provided with New Standard adaption and adaptation. Top side, adaption provided with Safety-Clicks. Bottom side with clamping bar.

# NEW STANDARD<sup>®</sup> TOOL HOLDERS AND INSERTS FOR OFFSETS AND FLATTENING

## Tool Holders

Holders suitable for use with various inserts for offset Z bends and for flattening, advantages:

- easy to use
- no more time-consuming tool alignment
- one tool holder can be used for multiple size inserts and applications

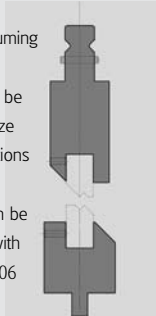

HU-001 Top Holder can be used in combination with either HU-005 or HU-006 Bottom Holder.

## HU-001

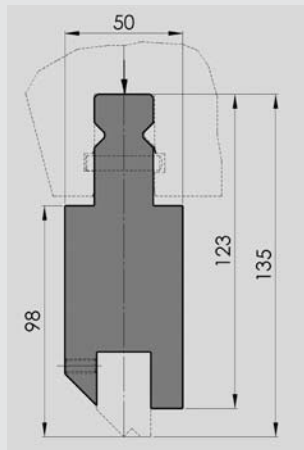

## HU-005

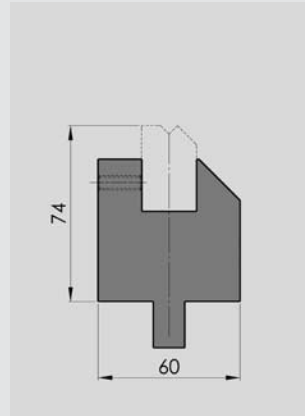

## HU-006

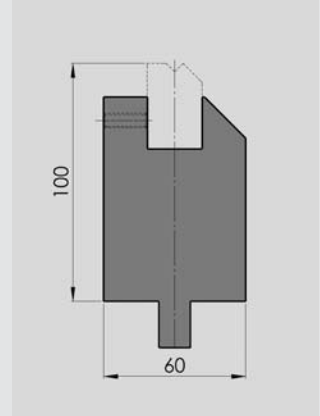

## INZU-001

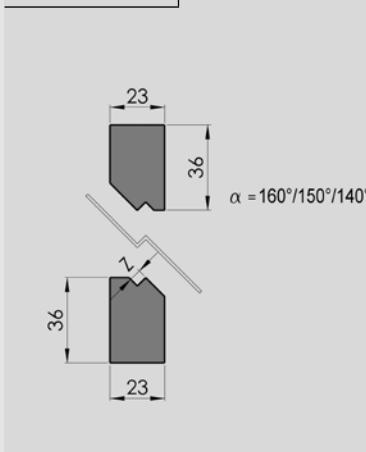

## INZU-002

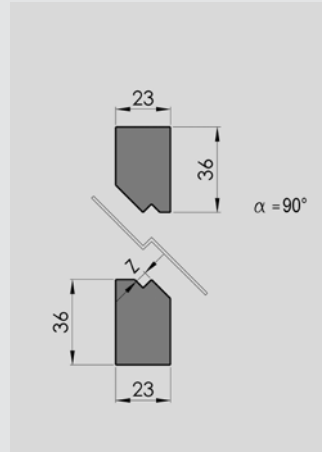

## INZU-003

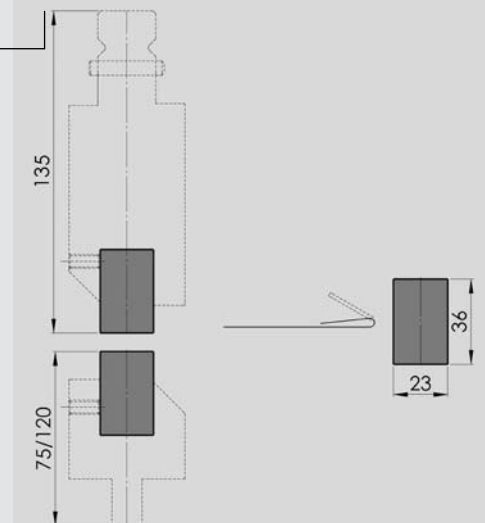

TYPE	LENGTH	Z	WEIGHT KG	MAX LOAD	PRICE	REMARKS
HU-001/1	515 mm		175	100 T/Mtr.		Top Holder, top provided with New Standard adaption and safety pins. Bottom suitable for inserts type INZU. Work height 98 mm incl. inserts.
HU-005/1	515 mm		13.4	100 T/Mtr.		Bottom Holder, bottom provided with the OZU adaption, 13x20 mm (WxH). Top suitable for inserts type INZU. Working height 74 mm incl. inserts.
HU-006/1	515 mm		19.3	100 T/Mtr.		Bottom Holder, bottom provided with the OZU adaption, 13x20 mm (WxH). Top suitable for inserts type INZU. Working height 100 mm incl. inserts.
INZU-001/Z1/1	515 mm	1.0 mm	6.7			
INZU-001/Z1.5/1	515 mm	1.5 mm	6.7	100 T/Mtr.		Set of inserts, top and bottom, for making offsets. Suitable for use in combination with holders HU-001, 005 and 006.
INZU-001/Z2/1	515 mm	2.0 mm	6.6			
INZU-001/Z2.5/1	515 mm	2.5 mm	6.6			
INZU-002/Z3/1	515 mm	3.0 mm	6.3			
INZU-002/Z3.5/1	515 mm	3.5 mm	6.3			
INZU-002/Z4/1	515 mm	4.0 mm	6.3			
INZU-002/Z4.5/1	515 mm	4.5 mm	6.3			
INZU-002/Z5/1	515 mm	5.0 mm	6.3			
INZU-002/Z5.5/1	515 mm	5.5 mm	6.3	100 T/Mtr.		Set of inserts, top and bottom, for making offsets. Suitable for use in combination with holders HU-001, 005 and 006.
INZU-002/Z6/1	515 mm	6.0 mm	6.3	(alpha=90°)		
INZU-002/Z6.5/1	515 mm	6.5 mm	6.3			
INZU-002/Z7/1	515 mm	7.0 mm	6.3			
INZU-002/Z7.5/1	515 mm	7.5 mm	6.3			
INZU-002/Z8/1	515 mm	8.0 mm	6.2			
INZU-002/Z10/1	515 mm	10.0 mm	8.5			
INZU-002/Z13/1	515 mm	13.0 mm	8.3			
INZU-003/1	515 mm		6.8	100 T/Mtr.		Insert to flatten or complete hem. For top and bottom flattening insert, order two INZU-003/1. Max sheet thickness 2mm. Suitable for use in combination with holders HU-001, 005 and 006.

# NEW STANDARD® RADIUS TOOLING HOLDERS - RADIUS TOOLING INSERTS

**HU-004**

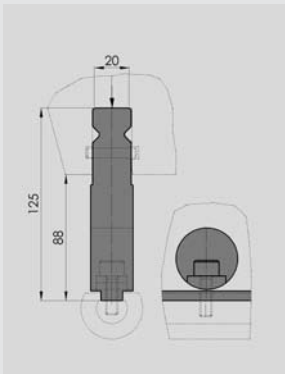

**HU-024**

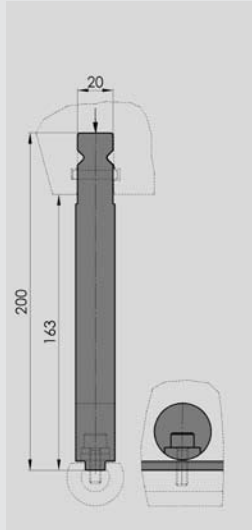

**HU-124**

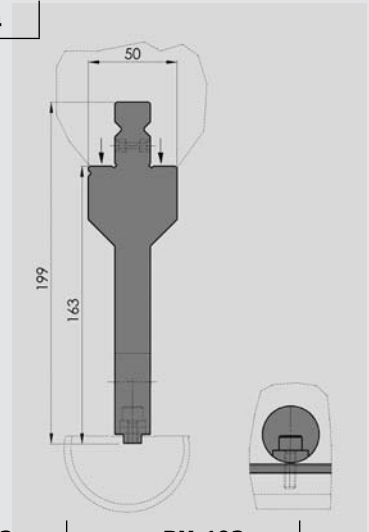

**RU-001**

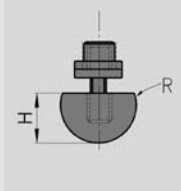

**RU-101**

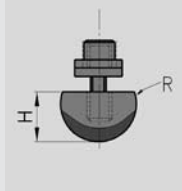

**RU-002**

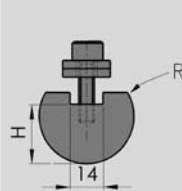

**RU-102**

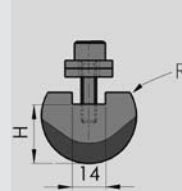

**RU-003**

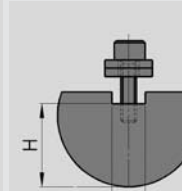

**RU-103**

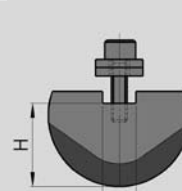

TYPE	LENGTH	R	H	WEIGHT	MAX LOAD	PRICE	REMARKS
				KG			
HU-004/1	515 mm			9.8	100 T/Mtr.		Holder suitable for various radius and flattening tools. Top provided with New Standard adaption, with safety pins. Working height dependent on the radius tools to be used.
HU-024/1	515 mm			15.1	100 T/Mtr.		Holder suitable for various radius and flattening tools. Top provided with New Standard adaption, with safety pins. Working height dependent on the radius tools to be used.
HU-124/1	515 mm			24.2	250 T/Mtr.		Holder suitable for various radius and flattening tools. Top provided with New Standard adaption, with safety keys. Working height dependent on the radius tools to be used.
RU-001/R7/1	515 mm	7 mm	11.5 mm	0.6			
RU-001/R7.5/1	515 mm	7.5 mm	11.5 mm	0.6			
RU-001/R8/1	515 mm	8 mm	13 mm	0.7	100 T/Mtr.		Radius tools Non-hardened. Radius 7- 10mm to be used in combination with holder type HU-004-024 and 124.
RU-001/R9/1	515 mm	9 mm	16 mm	1.0			
RU-001/R10/1	515 mm	10 mm	16 mm	1.2			
RU-002/R12.5/1	515 mm	12.5 mm	16 mm	1.6			
RU-002/R15/1	515 mm	15 mm	20 mm	2.4	100 T/Mtr.		Radius tools Non-hardened. Radius 12.5- 20mm to be used in combination with holder type HU-004-024 and 124.
RU-002/R17.5/1	515 mm	17.5 mm	22 mm	3.2			
RU-002/R20/1	515 mm	20 mm	24 mm	4.2			
RU-003/R25/1	515 mm	25 mm	29 mm	6.1			
RU-003/R30/1	515 mm	30 mm	34 mm	8.3	100 T/Mtr.		Radius tools Non-hardened. Radius 25- 50mm to be used in combination with holder type HU-004-024 and 124.
RU-003/R40/1	515 mm	40 mm	45 mm	12.9			
RU-003/R50/1	515 mm	50 mm	54 mm	21.3			
RU-101/R7/1	515 mm	7 mm	11.5 mm	0.6			
RU-101/R7.5/1	515 mm	7.5 mm	11.5 mm	0.6			
RU-101/R8/1	515 mm	8 mm	13 mm	0.7	175 T/Mtr.		Radius tools CNC-Deephardened®. Radius 7- 10mm to be used in combination with holder type HU-004-024 and 124.
RU-101/R9/1	515 mm	9 mm	16 mm	1.0			
RU-101/R10/1	515 mm	10 mm	16 mm	1.2			
RU-102/R12.5/1	515 mm	12.5 mm	16 mm	1.6			
RU-102/R15/1	515 mm	15 mm	20 mm	2.4	225 T/Mtr.		Radius tools CNC-Deephardened®. Radius 12.5- 20mm to be used in combination with holder type HU-004-024 and 124.
RU-102/R17.5/1	515 mm	17.5 mm	22 mm	3.2			
RU-102/R20/1	515 mm	20 mm	24 mm	4.2			
RU-103/R25/1	515 mm	25 mm	29 mm	6.1			
RU-103/R30/1	515 mm	30 mm	34 mm	8.3	250 T/Mtr.		Radius tools CNC-Deephardened®. Radius 25- 50mm to be used in combination with holder type HU-004-024 and 124.
RU-103/R40/1	515 mm	40 mm	45 mm	12.9			
RU-103/R50/1	515 mm	50 mm	54 mm	21.3			

**K-001/5**

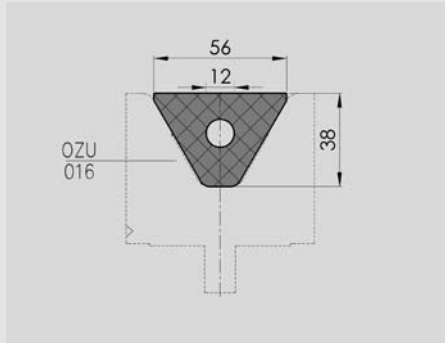

**K-003**

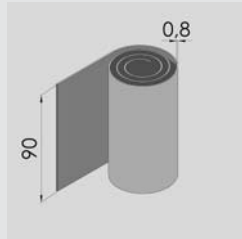

**K-004**

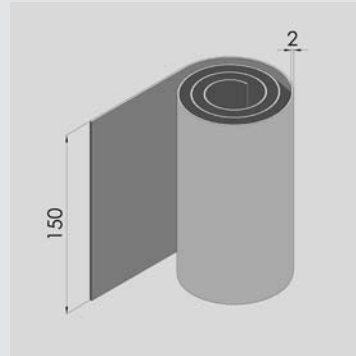

**K-005**

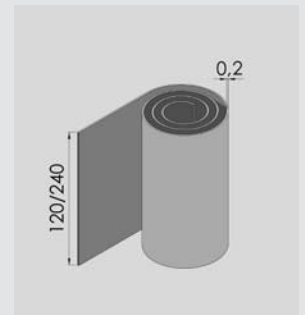

**Clamping System for foil**

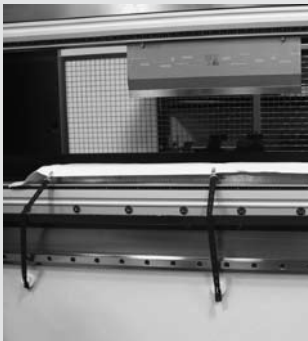

**INZU-005**

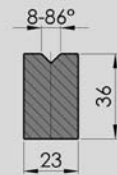

For use in holder type HU-005 and 006.

**INZU-006**



For use in holder type HU-005 and 006.

**INZU-007**

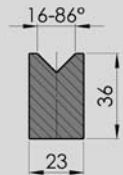

For use in holder type HU-005 and 006.

TYPE	LENGTH	WEIGHT	MAX LOAD	PRICE	REMARKS
<b>KG</b>					
K-001/5	ca 2100 mm				Adiprene inserts for bending material without marking. To be used in bottom tools type OZU-016. Use dependent on material type, thickness, angles and radius size. Available in 85 Shore A and 95 Shore A.
K-003	unlimited				Protective foil for bending material without marking. Use dependent on material type, thickness, angles, radius size and bending method.
K-004	unlimited				Protective foil for bending material without marking. Use dependent on material type, thickness, angles, radius size and bending method.
K-005/120	unlimited				NoMar Protective Cloth for bending material without marking. Use dependent on material type, thickness, angles, radius size and bending method, available in width 120 mm and 240 mm.
K-005/240	unlimited				
CLAMPING SYSTEM FOR K-003/4/5					Clamping system for protective foil/cloth K-003/K-004/K-005. 1 set consists of 6 magnets and 6 straps.
INZU-005/1	515 mm	0.5	20 T/Mtr.		Synthetic inserts for bending material without marking. To be used in bottom holders type HU-005 and HU-006. Use dependent on material type, thickness, angles and radius size.
INZU-006/1	515 mm	0.5			
INZU-007/1	515 mm	0.5			



**RU-004**

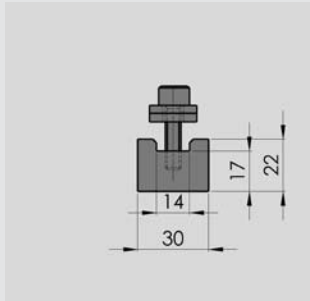

**DDU-001**

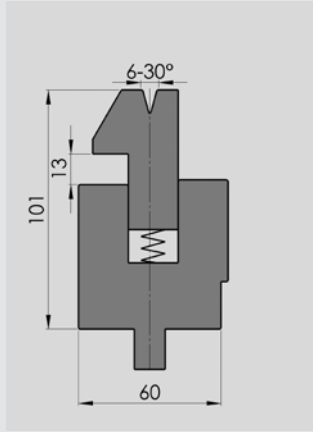

**DDU-002**

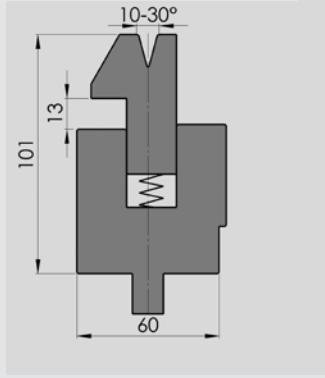

**DDU-003**

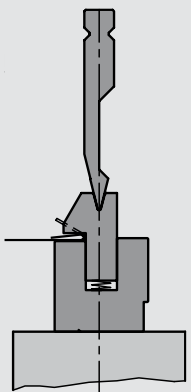
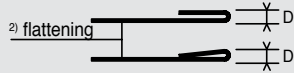
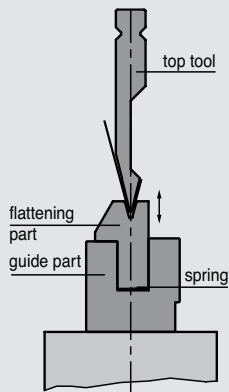
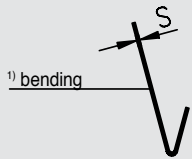
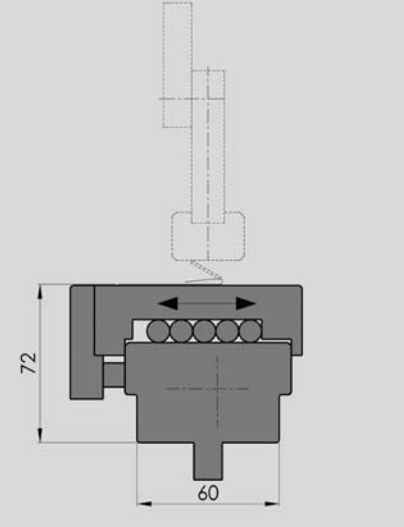

TYPE	LENGTH	WEIGHT KG	MAX LOAD	PRICE	REMARKS
RU-004/1	515 mm	2.4	100 T/Mtr.		Flattening tool to be used in combination with holder types HU-004-024-124. Max. sheet thickness 2 mm.
DDU-001/1	515 mm	20.0	60 T/Mtr.		Bending and flattening tool, provided with V=6 mm - 30°. Max. sheet thickness 1 mm. Flattening part operated by spring action, stroke 13 mm. Closed working height 88 mm.
DDU-002/1	515 mm	19.7	70 T/Mtr.		Bending and flattening tool, provided with V=10 mm - 30°. Max. sheet thickness 1.5 mm. Flattening part operated by spring action, stroke 13 mm. Closed working height 88 mm.
DDU-003/1	515 mm	23.7	100 T/Mtr.		Moving flattening bottom tool with rollers for material S=2-4 mm. Suitable for use in combination with flattening top tool. Working height 72 mm.

**TS 612 Adapter**

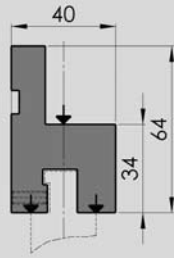

**TS 612 Adapter**  
EUROPEAN STYLE I TO AMERICAN STYLE ADAPTER

Bottom side with American Style adaptation and 1 clampig screw every 100 mm.

FOR USE WITH	STANDARD	OPTIONAL
American style top tools	●	

LENGTH	WEIGHT	MAX LOAD	PRICE
	KG		
1190 mm	14		
1530 mm	18		
1785 mm	21		
2040 mm	24		
2380 mm	28	Shoulder load	
2550 mm	30	100 T/meter	
3060 mm	36		
3655 mm	43		
4080 mm	49		
4250 mm	51		

**TS 802 Extender**

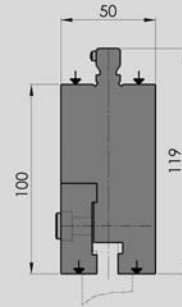

**TS 802 Extender**  
AMERICAN STYLE II TO AMERICAN STYLE EXTENDER

Bottom side with clamping plate.

FOR USE WITH	STANDARD	OPTIONAL
American style top tools	●	

LENGTH	WEIGHT	MAX LOAD	PRICE
	KG		
1190 mm	48		
1530 mm	61		
1785 mm	71		
2040 mm	82		
2380 mm	95	Shoulder load	
2550 mm	102	100 T/meter	
3060 mm	122		
3655 mm	146		
4080 mm	163		
4250 mm	170		

**TS 804 Adapter**

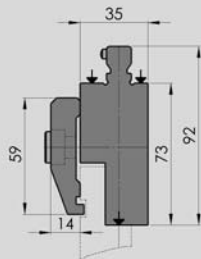

**TS 804 Adapter**  
AMERICAN STYLE II TO EUROPEAN STYLE I ADAPTER

Bottom side with clamping plate TK 031.

FOR USE WITH	STANDARD	OPTIONAL
European style I top tools	●	

LENGTH	WEIGHT	MAX LOAD	PRICE
	KG		
1190 mm	35		
1530 mm	45		
1785 mm	53		
2040 mm	61		
2380 mm	71	Shoulder load	
2550 mm	76	100 T/meter	
3060 mm	91		
3655 mm	109		
4080 mm	121		
4250 mm	126		

Note: Other lengths available on request.

OZU-811  Wila made  
American  
Style  
**200**  
12x30" R-1  
H-55  
10 kg/m  
max 400 kN/m  
1α-90° 

OZU-913  Wila made  
American  
Vintage  
**4"**  
630x86" R-059  
H-2.65  
84 lbs/ft  
max 27 tons ft  
1α-90°

BIU-403  Wila made  
New  
Standard  
Pro  
**100**  
96" R-1  
H-100  
23 kg/m  
max 600 kN/m

BIU-023  Wila made  
New  
Standard  
Premium  
**200**  
86" R-1  
H-163  
38 kg/m  
max 650 kN/m

**TOOLING**

# PRESS BRAKE PRODUCTIVITY CABINETS

In order to be able to store tools in an organized and safe way, Wila has put on the market its Press Brake Productivity Cabinet.

These tool cabinets are delivered standard with:

- 1 shallow drawer, bearing capacity of 100 kg, to store measuring tools, etc.
- A base with removable kick plates front and back to allow for easy movement with fork-lift or pallet truck.
- A tilting guard, so that only 1 drawer at a time can be opened.
- Lockable doors.
- A black rubber mat on top.
- 5 drawers with perforated bottom, bearing capacity of 200 kg each.

The distance between the drawers can be adjusted easily in steps of about 25 mm.

- The arrangement of the tool drawers can be adjusted according to the tools to be stored.
- Each drawer has two bottom plates made from practically indestructible nylon with milled slots designed especially to hold vertically all Wila tools according to their adaption widths. Each drawer also includes one nylon spacer plate.

- Wila has 2 bottom plates in the program.
  - Bottom plate type no. 22084 suitable for the OZU lower tools of the complete New Standard program and the BIU top tools of the American Style program.
  - Bottom plate type no. 22086 suitable for the BIU top tools of the complete New Standard program.
  - Drawers, bottom and spacer plates (type no. 22088) can be delivered separately.

Wila has more cabinet arrangements available, more information can be received upon request.

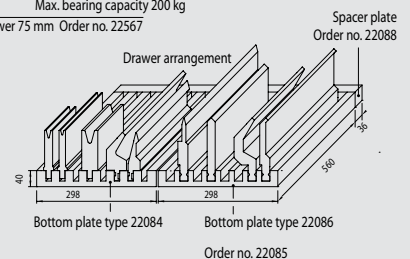
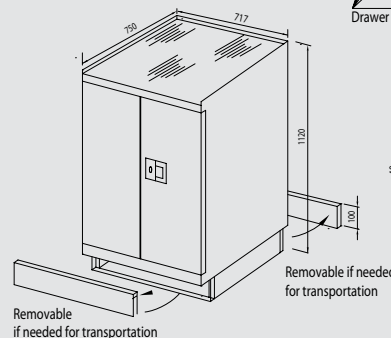
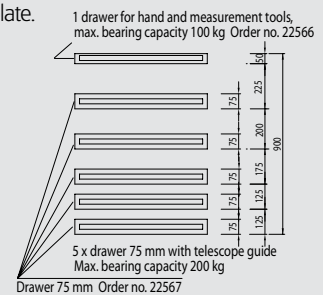
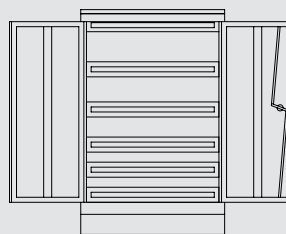

# TOOLING

# CUSTOM MADE

# TOOLING

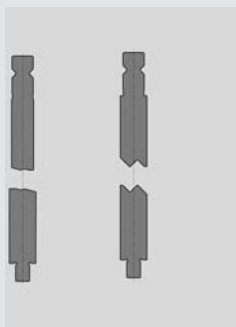

*Offset Tooling*

Aside from the before mentioned standard tools and accessories, we can supply Custom Made tools which can be manufactured completely according to the customer's needs. These tools can be made in any of the tooling style executions and to the specific length required, as well as with different methods of hardening.

It is also possible to segment the tools into the lengths desired by the customer, to allow, for example, the bending of box-shaped products. For top tools it is possible to provide tooling sets including horn sections (sections with a cut-out to accommodate parts with a reverse flange).

A number of possibilities are on this page.



*Horn*

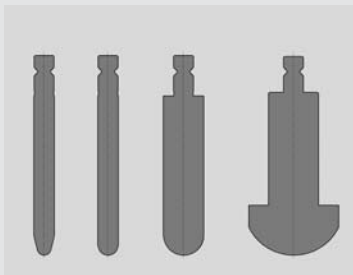

*Radius Tooling*



*Box Bending*



*Heavy Duty*



*Radius Bending*



*Special Application*

**UNPARALLELED WORLDWIDE COVERAGE**

# **GLOBAL SUPPORT FROM THE GLOBAL LEADER**

Being the global leader in the press brake tooling and accessories industry requires us to be involved at all levels, from the inception of a new press brake design, to the shop floor and the operator that will be running it. It also requires us to completely dedicate ourselves to our core business and not try to be many things to many people. At Wila, we have spent over 75 years focusing entirely upon the products that go between the ram and bed of our customers' press brakes, and to making their machines the most productive they can be.



As the world's largest independent manufacturer of press brake tooling, clamping and crowning systems, our network of global coverage includes relationships with all of the world's major press brake manufacturers. We constantly have a steady stream of engineers and various managers working with the major press brake builders to make sure that our products are perfectly matched to the capabilities of their machines. This assures the end user that they will receive maximum productivity from their press brakes and the very best support regardless of where they are located.

Being a truly global supplier enables us to work with customers that have manufacturing facilities in virtually any location. This includes multiple locations in the same country, or multiple locations in multiple countries.

Our team of dedicated business development managers provides continual training and support for our distributors. In working with the finest press brake distributors, we make it possible for our customers to make one phone call when they need assistance with their press brake, press brake tooling, control, or software. This provides them with single source responsibility, and virtually eliminates the possibility that they will get caught with a problem between multiple suppliers.

In purchasing a new press brake, you are most often making a commitment of at least ten years or more to that machine and the tooling, clamping, and crowning systems that it comes equipped with. Regardless of where you are located, when those components are made by Wila, you can rest assured that the Wila global support network will be right there with you.

## WORLD CLASS CUSTOMER

# WORLD CLASS SERVICE FOR WORLD CLASS PRODUCTS

When you purchase a new product, you are committing to a relationship with the supplier. When you need a product quickly, have a problem with a product, or just need some assistance in the proper use of it, you are most likely going to be stuck with the seller as the source of knowledge and customer service. At Wila, we place a premium on providing our customers with service that is the very best available, and equal to the quality of our industry leading products.

All of our punches, dies, clamping and crowning systems in standard lengths, and common accessories are normally in stock and ready for immediate shipment. Our MRP system provides us with maximum manufacturing flexibility and allows us to shift resources as required to provide special punches and dies and clamping and crowning systems in custom lengths with short lead times.

Our heavy investment in CAD-CAM technology and automated design capability enable us to receive drawings supplied to us by customers, make a few modifications, and turn them into a finished product in a short period of time. This includes punches with special tip radii, special punches designed for unique parts, dies with special V-openings, and more sophisticated solutions such as made to order clamping and crowning systems.



We also recognize that when you call for help, you want to speak to someone that is experienced in the use of our products and able to assist you with whatever needs you may have. That is why we employ only the finest and most technically qualified people, and continually invest in ongoing employee improvement programs.

At Wila, we view customer service as a key component of the overall Wila experience. We know that maintaining our position as the industry leader demands that we provide excellent customer service. We are confident that once you have had the Wila experience, you will never accept anything less. But you don't have to take our word for it. Just ask one of our customers.

# AIR BENDING TONNAGE CHART

Required press force at 90° air bending, force in ton/mtr.

The charts below give the appropriate tonnage to air bend mild steel.

Bending force for other metals:

Soft aluminium : Tons per unit length x 50%

Aluminium alloys heat treated : Tons per unit length x 100%

Stainless : Tons per unit length x 150%

Bottoming : Tonnage requirements are three to five times greater than for air bending.

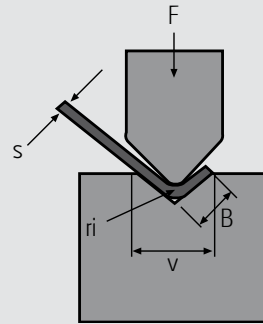

F = Tons per meter of workpiece

s = Material thickness

ri = Inside radius of formed part

v = V-die opening

B = Minimum flange

## Metric

V (mm)	4	6	8	10	12	16	20	24	30	40	50	60	80	100	120	160
V (inch)	0.157*	0.236*	0.315*	0.394*	0.472*	0.630*	0.787*	0.945*	1.181*	1.575*	1.969*	2.362*	3.150*	3.937*	4.724*	6.299*
B (outside mm)	2.8	4.2	5.6	7	8.6	11.5	14.4	17	21	29	36	42.4	56.5	71	85	114
ri (mm)	0.6	1	1.2	1.5	1.8	2.4	3	3.6	4.5	6	7.5	9	12	15	18	24

### Material Thickness

mm

0.5	4	2															
1		10	8	5.5	4.5												
1.2		16	12	9	7												
1.5			20	14	11	8	6										
2					22	15	11	9.5									
2.5						25	19	15	11								
3							28	22	17	12							
4								44	33	22.5	17						
5									55	37	29	22					
6										58	42	34					
8											83	65	45	35			
10												110	75	57	45		
12													116	85	68		
14														121	91	68	
15														143	112	79	
16														168	131	90	
18															172	119	
20															222	150	
25																254	

## Inch

V (inch)	0.250*	0.375*	0.500*	0.625*	0.750*	0.875*	1.000*	1.125*	1.500*	2.000*	2.500*
V (mm)	6.4	9.5	12.7	15.9	19.05	22.2	25.4	28.6	38.1	50.8	63.5
B (outside inch)	0.167*	0.265*	0.354*	0.442*	0.530*	0.619*	0.707*	0.795*	1.06*	1.414*	1.768*
ri (inch)	0.038*	0.056*	0.075*	0.094*	0.113*	0.131*	0.150*	0.169*	0.225*	0.300*	0.375*

### Material Thickness

Gauge Inches

20	0.036"	3.2	2.0														
18	0.048"	5.1	3.4	2.7	2.4												
16	0.060"		5.8	4.0	3.1	2.5											
14	0.075"			6.9	5.0	4.0	3.5										
12	0.105"					8.3	6.9	5.6									
11	0.120"						9.9	8.2	7.2								
10	0.135"						11.9	9.9	7.3	5.8							
3/16"	0.188"								14.3	12.2	7.5						
1/4"	0.250"									23.7	16.5	11.4					
5/16"	0.313"										27	19.7					
3/8"	0.375"										42.3	30.9					



# TONNAGE CHART FOR FLATTENING

## Mild steel

Rm≈42 KN/cm<sup>2</sup>  
Rm≈55-60.000 PSI

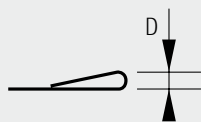

Rm≈42 KN/cm<sup>2</sup>  
Rm≈55-60.000 PSI



### Thickness

### Tonnage

### D

### Tonnage

### D

Mm	Inches	Ton/meter	US ton/ft	Mm	Inches	Ton/meter	US ton/ft	Mm	Inches
0.6	.024	12	4.0	2.3	.091	20	6.7	1.3	.051
0.8	.031	16	5.4	2.3	.091	30	10.1	1.7	.067
1.0	.039	20	6.7	2.4	.095	30	10.1	2.2	.087
1.2	.047	24	8.1	3.0	.118	40	13.4	2.5	.098
1.5	.059	30	10.1	4.4	.173	50	16.8	3.5	.138
2	.079	40	13.6	5.1	.201	60	20.2	4.2	.165

## Stainless steel

Rm≈70 KN/cm<sup>2</sup>  
Rm≈100.000 PSI



Rm≈70 KN/cm<sup>2</sup>  
Rm≈100.000 PSI



### Thickness

### Tonnage

### D

### Tonnage

### D

Mm	Inches	Ton/meter	US ton/ft	Mm	Inches	Ton/meter	US ton/ft	Mm	Inches
0.6	.024	20	6.7	2.3	.091	35	11.8	1.3	.051
0.8	.031	27	9.0	2.3	.091	50	16.8	1.7	.067
1.0	.039	34	11.4	2.4	.095	50	16.8	2.2	.087
1.2	.047	40	13.5	3.0	.118	80	26.9	2.5	.098
1.5	.059	50	16.8	4.4	.173	85	28.6	3.5	.138
2	.079	90	30.3	5.1	.201	120	40.4	4.7	.185

**THE COLD HARD TRUTH!**

# **CNC-DEEPHARDENING® VERSUS NITRIDE**

Due to improvements in quality and durability, press brake tooling is no longer a perishable commodity. When properly cared for and used within the correct range of applications, today's precision ground and hardened press brake tooling can often provide an extreme long usable service. That is not to say that it will simply last for ten years or more, but rather, it will provide performance that is the same or nearly the same as it did when it was brand new and right out of the box for that long or longer.

This is certainly not true of all press brake tooling. It is true however of high quality precision ground and hardened press brake tooling. As such, when purchasing tooling for a new press brake, today's press brake buyer is now more than ever making a long term decision. And as with any other long term business decision, you'll want to make the decision that will provide you with maximum productivity and the maximum return on your investment.

For additional technical information on Wila's proprietary CNC-Deephardening process, please request our six-page Product Bulletin: "CNC-Deephardening versus Nitride".

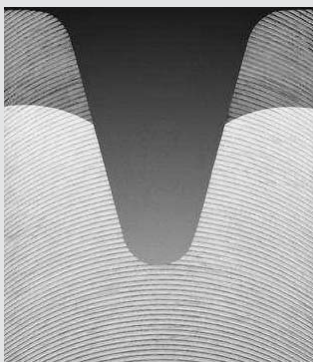

*Bottom tool with Wila's proprietary CNC-Deephardening® process applied.*

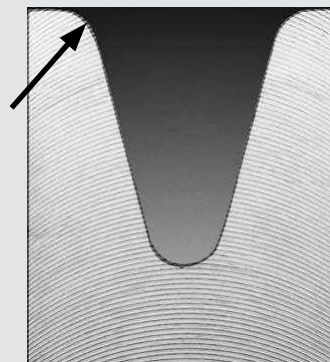

*Bottom tool with competitors Nitride process applied.*

## TERMS

Payment: terms are based on individual arrangements for all items  
Prices are EXW Lochem, The Netherlands.

Package: We charge 1,5% of the price list price with a minimum of  
€ 10 per order.

Returns: Prior approval, a Wila RMA number and shipping instructions  
are required prior to any material return. A handling charge of 20% is  
made on all standard items returned. Special tooling cannot be  
returned.

Claims: All claims and shortages must be made by e-mail, fax or mail  
within 10 days of invoice date.

Our deliveries are subject to the "General Conditions for the supply of  
mechanical, electrical and electronic products", in short "Orgalime S  
2000". Licensed for use by Wila b.v.; Licence N° 03/02/01. (Orgalime  
groups the central trade federations of the mechanical, electrical,  
electronic and metalworking industries in eighteen European countries  
and provides liaison between these organisations in the legal,  
technical and economic fields.

Orgalime "Diamant" building,

Boulevard A. Reyers 80, B - 1030 Bruxelles

Tel : (32) 2 706 82 35 - Fax : (32) 2 706 82 50 e-mail : secretariat@  
orgalime.org

## DISCLAIMER

No part of this publication may be reproduced and/or published by  
means of printing, photocopying, microfilm or otherwise, without the  
prior written permission of Wila.

Although the data recorded in this publication were compiled by the  
author(s) with the utmost care, Wila accepts no liability whatsoever for  
any incomplete or inaccurate information which may nonetheless have  
been included. Our products are constantly improved, which means that  
the current model may differ from the examples given here.

## SAFETY WARNING

All Wila standard top tools include a safety device incorporated in the  
adaption. New Standard Premium, New Standard Pro, American Style  
either have a Safety-Click or fixed safety pins / keys.

When using top tools and bottom tools on a press brake, a forming  
system is created which requires analysis to determine the appropriate  
safe guarding for operator safety and protection. The load ratings of all  
tooling should be analyzed for the application.

It is the user's responsibility to ensure that the point of operation is  
effective and all applicable safety requirements are met.

**WILA B.V.**

P.O. box 60

NL-7240 AB Lochem

The Netherlands

Phone +31 (0)573 28 98 00

Phone sales: +31 (0)573 28 98 50

Fax +31 (0)573 25 75 97

E-mail [info@wila.nl](mailto:info@wila.nl)

[www.wila.nl](http://www.wila.nl)

